

Electromechanical Linear Actuators

Product Overview



ENGINEERING YOUR SUCCESS.



WARNING – USER RESPONSIBILITY

FAILURE OR IMPROPER SELECTION OR IMPROPER USE OF THE PRODUCTS DESCRIBED HEREIN OR RELATED ITEMS CAN CAUSE DEATH, PERSONAL INJURY AND PROPERTY DAMAGE.

- This document and other information from Parker-Hannifin Corporation, its subsidiaries and authorized distributors provide product or system options for further investigation by users having technical expertise.
- The user, through its own analysis and testing, is solely responsible for making the final selection of the system and components and assuring that all performance, endurance, maintenance, safety and warning requirements of the application are met. The user must analyze all aspects of the application, follow applicable industry standards, and follow the information concerning the product in the current product catalog and in any other materials provided from Parker or its subsidiaries or authorized distributors.
- To the extent that Parker or its subsidiaries or authorized distributors provide component or system options based upon data or specifications provided by the user, the user is responsible for determining that such data and specifications are suitable and sufficient for all applications and reasonably foreseeable uses of the components or systems.

Parker Hannifin

The global leader in motion and control technologies

A world class player on a local stage

Global Product Design

Parker Hannifin has more than 40 years experience in the design and manufacturing of drives, controls, motors and mechanical products. With dedicated global product development teams, Parker draws on industry-leading technological leadership and experience from engineering teams in Europe, North America and Asia.

Local Application Expertise

Parker has local engineering resources committed to adapting and applying our current products and technologies to best fit our customers' needs.

Manufacturing to Meet Our Customers' Needs

Parker is committed to meeting the increasing service demands that our customers require to succeed in the global industrial market. Parker's manufacturing teams seek continuous improvement through the implementation of lean manufacturing methods throughout the process. We measure ourselves on meeting our customers' expectations of quality and delivery, not just our own. In order to meet these expectations, Parker operates and continues to invest in our manufacturing facilities in Europe, North America and Asia.

Electromechanical Worldwide Manufacturing Locations

Europe

Littlehampton, United Kingdom
Dijon, France
Offenburg, Germany
Filderstadt, Germany
Milan, Italy

Asia

Wuxi, China
Jangan, Korea
Chennai, India

North America

Rohnert Park, California
Irwin, Pennsylvania
Charlotte, North Carolina
New Ulm, Minnesota



Offenburg, Germany

Local Manufacturing and Support in Europe

Parker provides sales assistance and local technical support through a network of dedicated sales teams and authorized technical distributors throughout Europe.

For contact information, please refer to the Sales Offices on the back cover of this document or visit www.parker.com



Milan, Italy



Littlehampton, UK



Filderstadt, Germany



Dijon, France

Parker Hannifin 4

Markets and Applications 6

Technical Features..... 8

Rod-Style Linear Handling Actuators 11

 ETH - High Force Electro Thrust Cylinder 12

Rodless Linear Handling Actuators 19

 HPLA - Linear Actuator with Plastic-Sheathed Rollers..... 20

 HLR - High Load Rodless Linear Actuator 24

 OSP-E..BHD - Belt Actuator with Integrated Ball Bearing 32

 OSP-E..B - Belt Actuator with Internal Plain Bearing Guide 35











 OSP-E..SB - Ball Screw Actuator with Internal Plain Bearing Guide 38

 OSP-E..ST - Trapezoidal Screw Actuator with Internal Plain Bearing Guide 40

 OSP-E..BV - Vertical Belt Actuator with Integrated Ball Bearing Guide..... 42

 HMR - Electromechanical Linear Actuator 46

Markets and Applications









	Rod-Style Linear Handling Actuators	Rodless Linear Handling Actuators			
					
Product	ETH	HPLA	HLR	OSP-E..B	OSP-E..SB
Description	High Force Electro Thrust Cylinder	Linear Actuator with Plastic- Sheathed Rollers	Linear Actuator	Belt Actuator with Internal Plain Bearing Guide	Ball Screw Actuator with Internal Plain Bearing Guide
Factory automation	<input type="checkbox"/>	<input type="checkbox"/>	<input type="checkbox"/>	<input type="checkbox"/>	<input type="checkbox"/>
Material handling	<input type="checkbox"/>	<input type="checkbox"/>	<input type="checkbox"/>	<input type="checkbox"/>	<input type="checkbox"/>
Material forming	<input type="checkbox"/>				<input type="checkbox"/>
Machines tools	<input type="checkbox"/>				<input type="checkbox"/>
Textile machines	<input type="checkbox"/>	<input type="checkbox"/>	<input type="checkbox"/>	<input type="checkbox"/>	<input type="checkbox"/>
Robotics	<input type="checkbox"/>			<input type="checkbox"/>	<input type="checkbox"/>
Packaging machines	<input type="checkbox"/>			<input type="checkbox"/>	<input type="checkbox"/>
Printing industry	<input type="checkbox"/>			<input type="checkbox"/>	<input type="checkbox"/>
Automotive industry / In-plant	<input type="checkbox"/>	<input type="checkbox"/>	<input type="checkbox"/>	<input type="checkbox"/>	<input type="checkbox"/>
Food, pharma & beverage	<input type="checkbox"/>				<input type="checkbox"/>
Life science (Medical instruments)	<input type="checkbox"/>	<input type="checkbox"/>	<input type="checkbox"/>		<input type="checkbox"/>
Life science (Diagnostic)					<input type="checkbox"/>
See details	(Page 12)	(Page 20)	(Page 24)	(Page 32)	(Page 35)
Product catalogue	 192-550017	 192-580011	 192-510210	 PDE2705TCUK	 PDE2705TCUK

Rodless Linear Handling Actuators



OSP-E..ST	OSP-E..BV	OSP-E..BHD	HMR-S	HMR-B
Trapezoidal Screw Actuator with Internal Plain Bearing Guide	Vertical Belt Actuator with Integrated Ball Bearing Guide (z-axis)	Belt Actuator with Integrated Ball Bearing Guide	Ball Screw Actuator with Integrated Double Ball Bearing Guide	Belt Actuator with Integrated Double Ball Bearing Guide
■	■	■	■	■
■	■	■	■	■
		■	■	■
		■	■	■
■	■	■	■	■
■	■	■	■	■
	■	■	■	■
■		■	■	■
■		■	■	■
■	■		■	■
■			■	
■				
(Page 38)	(Page 40)	(Page 42)	(Page 46)	(Page 46)
PDE2705TCUK	PDE2705TCUK	PDE2705TCUK	PDE2720TCUK	PDE2720TCUK





Technical Features

	Rod-Style Linear Handling Actuators	Rodless Linear Handling Actuators			
					
Product	ETH	HPLA	HLR	OSP-E..B	OSP-E..SB
Description	High Force Electro Thrust Cylinder	Linear Actuator with Plastic- Sheathed Rollers	Linear Actuator	Belt Actuator with Internal Plain Bearing Guide	Ball Screw Actuator with Internal Plain Bearing Guide
Size for product family	5	3	2	3	3
max. Stroke* [mm]	2000	9560	8230	5000	3200
max. Thrust force* [N]	114 000	5457	1350	425	1500
max. Load* [N]	-	8200	5900	850	3000
max. Speed at stroke* [mm/s]	1707	5000	5000	5000	1250
max. Acceleration* [m/s ²]	15	10	10	10	5
min. accuracy* [mm]	±0,03	±0,05	±0,05	±0,05	±0,05
min. Repeatability* [µm]	-	-	-	-	-
IP Protection	IP54 (IP65 optional)	IP20 (IP30 optional)	IP20	IP54	IP54
See details	(Page 12)	(Page 20)	(Page 24)	(Page 32)	(Page 35)
Product catalogue	 192-550017	 192-580011	 192-510210	 PDE2705TCUK	 PDE2705TCUK

* depending on size/option
 n.a. not available

Rodless Linear Handling Actuators



OSP-E..ST	OSP-E..BV	OSP-E..BHD	HMR-S	HMR-B
Trapezoidal Screw Actuator with Internal Plain Bearing Guide	Vertical Belt Actuator with Integrated Ball Bearing Guide (z-axis)	Belt Actuator with Integrated Ball Bearing Guide	Ball Screw Actuator with Integrated Double Ball Bearing Guide	Belt Actuator with Integrated Double Ball Bearing Guide
3	2	4	5	5
2500	1500	7000	4000	6000
2500	1490	3120	5500	4000
1500	3000	15000	39900	39900
150	5000	5000	1600	5000
k.A.	20	50	10	50
±0,5	±0,05	±0,05	±0,02	±0,05
-	-	-	-	-
IP54	IP20	IP54	IP54	IP54
(Page 38)	(Page 40)	(Page 42)	(Page 46)	(Page 46)
				
PDE2705TCUK	PDE2705TCUK	PDE2705TCUK	PDE2720TCUK	PDE2720TCUK

Rod-Style Linear Handling Actuators



ETH

ETH - High Force Electro Thrust Cylinder

Overview

Description

The ETH electro cylinder closes the gap between pneumatic and hydraulic actuators; it can act as a suitable alternative to both in many applications and can have the added benefit of increasing the reliability of the production process. Taking the costs for air and oil into consideration, you will find that in most cases an electromechanical system such as the ETH electro cylinder offers the more economical solution. Combined with a wide choice of accessories, the ETH becomes a highly customisable solution, suitable for a variety of applications.

Typical applications



- **Material handling and feed systems**
 - wood working and plastics industries
 - vertical actuators for loading machine tools
 - in the textile industry for tensioning / gripping textile fabrics
 - in the automotive industry for transporting and feeding components
- **Testing equipment and laboratory applications**
- **Valve and flap actuation**
- **Pressing**
- **Packaging machinery**
- **Process automation in the food and beverage industry**

Features

- **Unrivalled power density - high forces and small frame sizes**
- **Cabling can be concealed in the profile**
- **Accessories with integrated force sensors help to spread and even to control forces precisely**
- **Optimized for safe handling and simple cleaning**
- **High service life**
- **Reduced maintenance costs thanks to lubricating access in the cylinder flange**
- **Easy replacement due to pneumatic ISO flange norm (DIN ISO 15552:2005-12) conformity**
- **Integrated anti-rotation device**
- **Reduced noise emission**
- **All from one source:**
 We offer the complete drive train: Drive controllers, motors and gearboxes to match the Electro Cylinder



Technical Characteristics - Overview

Type	ETH Electro Cylinder
Frame sizes	ETH032 / ETH050 / ETH080 / ETH100 / ETH125
Screw lead	5, 10, 16, 20 mm
Stroke	up to 2000 mm
Traction/thrust force	up to 114000 N
Speed	up to 1.3 m/s
Acceleration	up to 15 m/s ²
Equivalent dynamic axial force at a lifetime of 2500 km	up to 49600 N
Efficiency	up to 90 %
Repeatability	up to ± 0.03 mm
Protection classes	IP54 IP54 with stainless steel screws IP65
Drive	Inline: Axial drive or parallel drive with high performance toothed belt
Directives	2011/65/EC: Conform to RoHS  RoHS 2014/34/EU Equipment group II Category 2, authorized for gas atmospheres zone 1 and zone 2
Classification	ETH032, 050:  II 2G Ex h IIC T4 Gb ETH080:  II 2G Ex h IIB T4 Gb Conformity certificate number: EPS 13 ATEX 2 592 X (X: there are special specification of use, please observe the intended use of the ATEX Cylinder)

We also offer customized solutions:

If your application requires a special version of the ETH cylinder, please contact your local Parker Sales Office.

- Customized mountings and rod ends
- Mounting of customer motors
- Preparation of the cylinder for use under aggressive environmental conditions
- Overlong thrust rod
- Polished thrust rod
- Thrust rod hard-chrome plated

Product Design

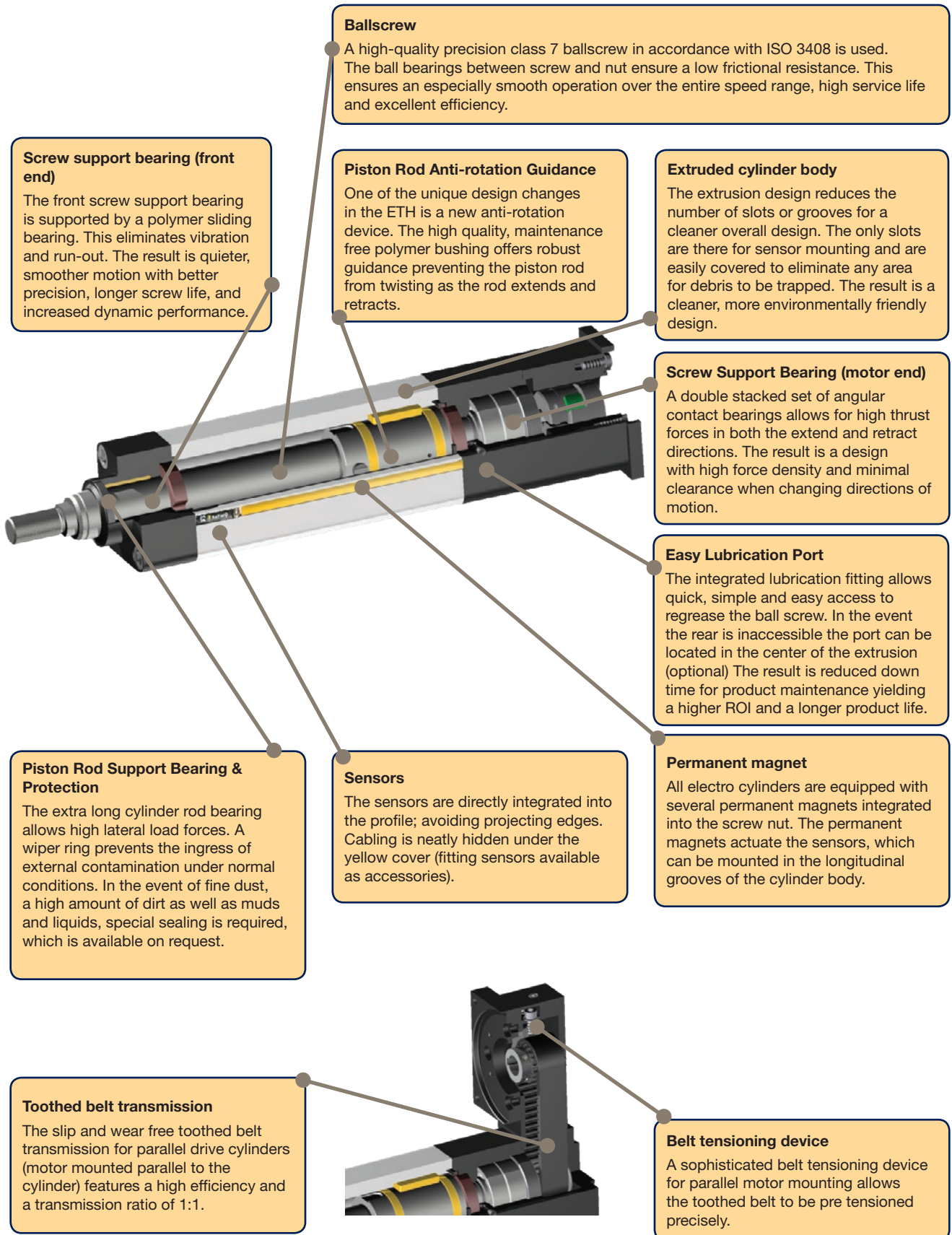

Ballscrew

A high-quality precision class 7 ballscrew in accordance with ISO 3408 is used. The ball bearings between screw and nut ensure a low frictional resistance. This ensures an especially smooth operation over the entire speed range, high service life and excellent efficiency.

Screw support bearing (front end)

The front screw support bearing is supported by a polymer sliding bearing. This eliminates vibration and run-out. The result is quieter, smoother motion with better precision, longer screw life, and increased dynamic performance.

Piston Rod Anti-rotation Guidance

One of the unique design changes in the ETH is a new anti-rotation device. The high quality, maintenance free polymer bushing offers robust guidance preventing the piston rod from twisting as the rod extends and retracts.

Extruded cylinder body

The extrusion design reduces the number of slots or grooves for a cleaner overall design. The only slots are there for sensor mounting and are easily covered to eliminate any area for debris to be trapped. The result is a cleaner, more environmentally friendly design.

Screw Support Bearing (motor end)

A double stacked set of angular contact bearings allows for high thrust forces in both the extend and retract directions. The result is a design with high force density and minimal clearance when changing directions of motion.

Easy Lubrication Port

The integrated lubrication fitting allows quick, simple and easy access to regrease the ball screw. In the event the rear is inaccessible the port can be located in the center of the extrusion (optional) The result is reduced down time for product maintenance yielding a higher ROI and a longer product life.

Piston Rod Support Bearing & Protection

The extra long cylinder rod bearing allows high lateral load forces. A wiper ring prevents the ingress of external contamination under normal conditions. In the event of fine dust, a high amount of dirt as well as muds and liquids, special sealing is required, which is available on request.

Sensors

The sensors are directly integrated into the profile; avoiding projecting edges. Cabling is neatly hidden under the yellow cover (fitting sensors available as accessories).

Permanent magnet

All electro cylinders are equipped with several permanent magnets integrated into the screw nut. The permanent magnets actuate the sensors, which can be mounted in the longitudinal grooves of the cylinder body.

Toothed belt transmission

The slip and wear free toothed belt transmission for parallel drive cylinders (motor mounted parallel to the cylinder) features a high efficiency and a transmission ratio of 1:1.

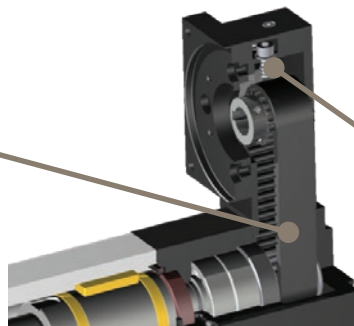

Belt tensioning device

A sophisticated belt tensioning device for parallel motor mounting allows the toothed belt to be pre tensioned precisely.

Technical Characteristics

Cylinder size type	Unit	ETH032			ETH050			ETH080	
		M05	M10	M16 ⁴⁾	M05	M10	M20 ⁴⁾	M05	M10
Screw lead	[mm]	5	10	16	5	10	20	5	10
Screw diameter	[mm]	16			20			32	

Travels, speeds and accelerations

Available strokes ¹⁾²⁾	[mm]	continuous from 50-1000 & standard strokes			continuous from 50-1200 & standard strokes			continuous from 100-1600 & standard strokes	
Max. permissible speed at stroke =									
50-400 mm	[mm/s]	333	667	1067	333	667	1333	267	533
600 mm	[mm/s]	286	540	855	333	666	1318	267	533
800 mm	[mm/s]	196	373	592	238	462	917	267	533
1000 mm	[mm/s]	146	277	440	177	345	684	264	501
1200 mm	[mm/s]	-	-	-	139	270	536	207	394
1400 mm	[mm/s]	-	-	-	-	-	-	168	320
1600 mm	[mm/s]	-	-	-	-	-	-	140	267
Max. Acceleration	[m/s ²]	4	8	12	4	8	15	4	8

Forces

Max. axial traction/thrust force motor inline	[N]		3700	2400		7000	4400		25 100
Max. axial traction/thrust force ³⁾ Motor parallel	[N]	3600	3280	2050	9300	4920	2460	17 800	11 620
Equivalent dynamic axial force at a lifetime of 2500 km	[N]	1130	1700	1610	2910	3250	2740	3140	7500

Max. transmissible torque / force constant

Max. transmissible torque inline motor	[Nm]	3.2	6.5	6.8	8.2	12.4	15.6	15.7	44.4
Max. transmissible torque ³⁾ Motor parallel	[Nm]	3.5	6.4		9.1	9.3		17.5	22.8
Force constant motor inline ⁵⁾	[N/Nm]	1131	565	353	1131	565	283	1131	565
Force constant motor parallel ⁵⁾	[N/Nm]	1018	509	318	1018	509	254	1018	509

Weight ⁶⁾

Weight of base unit with zero stroke (incl. piston rod)	[kg]	1.2	1.2	1.4	2.2	2.2	2.4	7.1	7.5
Additional weight of inline unit	[kg]	0.7			1.0			3.2	
Additional weight of parallel unit	[kg]	0.8			1.0			3.1	
Mass of additional stroke (incl. piston rod)	[kg/m]	4.5			8.2			18.2	
Weight of piston rod with zero stroke	[kg]	0.06			0.15			0.59	
Weight of piston rod - additional length	[kg/m]	0.99			1.85			4.93	

Mass moments of inertia

Motor parallel without stroke	[kgmm ²]	8.3	8.8	14.1	30.3	30.6	38.0	215.2	213.6
Motor inline without stroke	[kgmm ²]	7.1	7.6	12.9	25.3	25.7	33.1	166.2	164.5
Parallel/inline motor per meter	[kgmm ² /m]	41.3	37.6	41.5	97.7	92.4	106.4	527.7	470.0

Accuracy: Bidirectional Repeatability (ISO230-2)

Motor inline	[mm]	±0.03							
Motor parallel	[mm]	±0.05							

Efficiency

Motor inline	the efficiency includes all friction torques	[%]	90						
Motor parallel		[%]	81						

Ambient conditions

Operating Temperature	[°C]	-10...+70							
Ambient temperature	[°C]	-10...+40							
Storage temperature	[°C]	-20...+40							
Humidity	[%]	0...95 % (non-condensing)							
Location height range	[m]	max. 3000							

¹⁾ "Order Code" (page 52) & "Preferred Stroke Length" (page 54), ²⁾ Intermediate stroke lengths may be interpolated.

³⁾ Applies only for motor speed < 100 min⁻¹. Transmissible torque depending on the motor speed n Motor parallel see page 15,

⁴⁾ ATEX on request only, ⁵⁾ The efficiency factors are included in the force constants.

⁶⁾ Weight without rod-end and mounting option.

Cylinder size type	Unit	ETH100		ETH125	
		M10	M20	M10	M20
Screw lead	[mm]	10	20	10	20
Screw diameter	[mm]	50		63	

Travels, speeds and accelerations

Available strokes ¹⁾²⁾	[mm]	continuous from 200-2000 & standard strokes		continuous from 200-2000 & standard strokes	
Max. permissible speed at stroke =					
100-400 mm	[mm/s]	400	800	417	833
500 mm	[mm/s]	400	747	417	807
600 mm	[mm/s]	333	622	395	684
800 mm	[mm/s]	241	457	290	514
1000 mm	[mm/s]	185	354	224	405
1200 mm	[mm/s]	148	284	180	329
1400 mm	[mm/s]	122	235	148	275
1600 mm	[mm/s]	102	198	125	234
2000 mm	[mm/s]	76	148	94	170
Max. Acceleration	[m/s ²]	8	10	8	10

Forces

Max. axial traction/thrust force motor inline	[N]		56 000	88 700	114 000
Max. axial traction/thrust. ³⁾ Motor parallel	[N]	54 800	50 800	76 300	81 400
Equivalent dynamic axial force at a lifetime of 2500 km	[N]	18 410	27 100	27 140	49 600

Max. transmissible torque / force constant

Max. transmissible torque inline motor	[Nm]	100	200	150	400
Max. transmissible torque. ³⁾ Motor parallel	[Nm]	108	200	150	320
Force constant motor inline ⁴⁾	[N/Nm]	565	283	565	283
Force constant motor parallel ⁴⁾	[N/Nm]	509	254	509	254

Weight ⁵⁾

Weight of base unit with zero stroke (incl. piston rod)	[kg]	21	24	56	64
Additional weight of inline unit	[kg]	12		27	
Additional weight of parallel unit	[kg]	21		51	
Mass of additional stroke (incl. piston rod)	[kg/m]	38		62	
Weight of piston rod with zero stroke	[kg]	1.2		2.9	
Weight of piston rod - additional length	[kg/m]	7.7		14.4	

Mass moments of inertia

Motor parallel without stroke	[kgmm ²]	5860	6240	17 050	17 990
Motor inline without stroke	[kgmm ²]	2240	2620	12 960	13 400
Parallel/inline motor per meter	[kgmm ² /m]	4270	4710	10 070	10 490

Accuracy: Bidirectional Repeatability (ISO230-2)

Motor inline	[mm]	±0.03			
Motor parallel	[mm]	±0.05			

Efficiency

Motor inline	the efficiency includes all friction torques	[%]	90		
Motor parallel		[%]	81		

Ambient conditions

Operating Temperature	[°C]	-10...+70			
Ambient temperature	[°C]	-10...+40			
Storage temperature	[°C]	-20...+40			
Humidity	[%]	0...95 % (non-condensing)			
Location height range	[m]	max. 3000			

¹⁾ "Order Code" (page 52), ²⁾ Intermediate stroke lengths may be interpolated.

³⁾ Applies only for motor speed < 100 min⁻¹. Transmissible torque depending on the motor speed n Motor parallel see page 15,

⁴⁾ The efficiency factors are included in the force constants, ⁵⁾ Weight without rod-end and mounting option..

Technical Data apply under normal conditions and only for the individual operating and load modes. In the case of compound loads, it is necessary to verify in accordance with normal physical laws and technical standards whether individual ratings should be reduced. In case of doubt please contact Parker.

Dimensions

Electro Cylinder

prepared for inline motor mounting

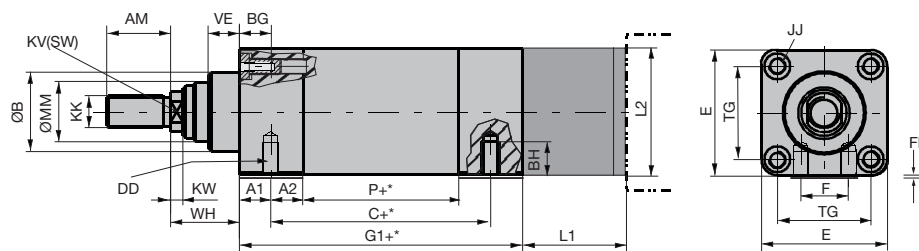

Electro Cylinder

prepared for parallel motor mounting

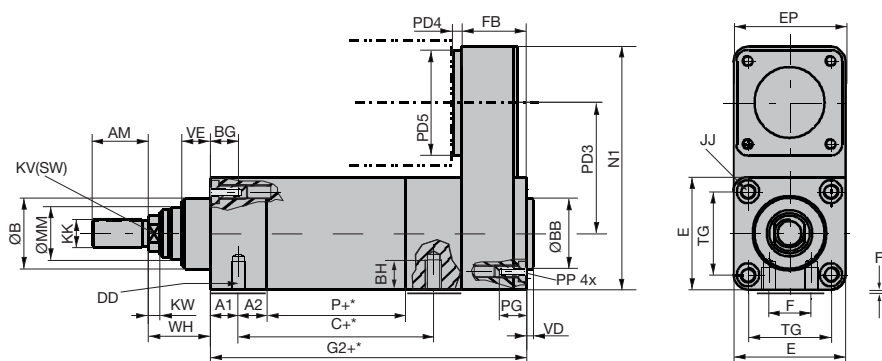

+* = Measure + length of desired stroke

Dimensions Standard & ATEX (IP-Version)

Cylinder size	Unit	ETH032			ETH050			ETH080		ETH100		ETH125	
		M05	M10	M16	M05	M10	M20	M05	M10	M10	M20	M10	M20
Screw lead													
C	[mm]	93.6 (93.6)	102.6 (102.6)	106.6 (106.6)	99.5 (100.5)	105.5 (106.5)	117.5 (118.5)	141.5 (142.5)	159.5 (160.5)	- 2)		- 2)	
G1	[mm]	133 (180.5)	142 (189.5)	146 (193.5)	154 (198.5)	160 (204.5)	172 (216.5)	197 (259.5)	215 (277.5)	323 (349.5)	361 (387.5)	461 (487.5)	549 (575.5)
G2	[mm]	180.5 (228.5)	189.5 (237.5)	193.5 (241.5)	194 (239)	200 (245)	212 (257)	257 (320)	275 (338)	451 (478.0)	489 (516.0)	624 (651.0)	712 (739.0)
P	[mm]	66	75	79	67	73	85	89	107	162	200	192	280
A1	[mm]	14 (60)			15.5 (58.5)			21 (82)		- 2)		- 2)	
A2	[mm]	17			18.5			32		- 2)		- 2)	
AM	[mm]	22			32			40		70		96	
BG (=BN+BS)	[mm]	16			25			26		32		44	
BN Usable length of thread	[mm]	11			20			20		22		33	
BS Depth of width across flat (without thread)	[mm]	5			5			6		10		11	
BH	[mm]	9			12.7			18.5		- 2)		- 2)	
DD mount thread ¹⁾	[mm]	M6x1.0			M8x1.25			M12x1.75		- 2)		- 2)	
E	[mm]	46.5			63.5			95		120		150	
EP	[mm]	46.5			63.5			95		175		220	
F	[mm]	16			24			30		- 2)		- 2)	
FF	[mm]	0.5			0.5			1.0		0		0	
JJ	[mm]	M6x1.0			M8x1.25			M10x1.5		M16x2		M20x2.5	
PP	[mm]	M6x1.0			M8x1.25			M10x1.5		M16x2		M20x2.5	
PG (Thread depth on the PA housing)	[mm]	BG (=BN+BS)			BG (=BN+BS)			BG (=BN+BS)		26		35	
KK	[mm]	M10x1.25			M16x1.5			M20x1.5		M42x2		M48x2	
KV	[mm]	10			17			22		46		55	
ØMM h9	[mm]	22			28			45		70		85	
TG	[mm]	32.5			46.5			72		89		105	
KW	[mm]	5			6.5			10		10		10	
N1	[mm]	126			160			233.5		347		450	
FB	[mm]	47.5 (48)			40 (40.5)			60 (60.5)		128 (128.5)		163 (163.5)	
VD	[mm]	4			4			4		4		5	
ØBB	[mm]	30 d11			40 d11			45 d11		90 d9		110 d8	
VE	[mm]	12			16			20		20		20	
WH	[mm]	26			37			46		51		53	
ØB	[mm]	30 d11			40 d11			60 d11		90 d8		110 d8	

¹⁾ Thread "DD" is only mandatory for mounting method "F".

²⁾ ETH100, ETH125 does not have a mounting thread on the underside.

Accessories for ETH cylinder

Outrigger bearing



Function of outrigger bearing:

- Additional stability and precision
- Anti-rotation device for higher torques
- Absorption of lateral forces

Initiators / Limit switches



Mounting methods

Foot mounting



Mounting flanges



Centre trunnion mounting

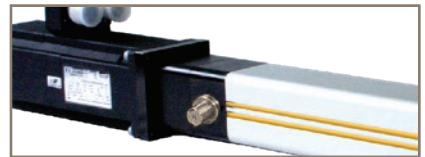

Front and rear plate



Rear clevis

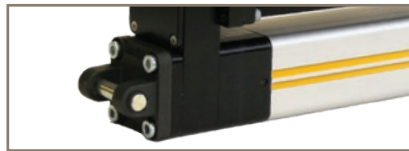

Rear eye mounting

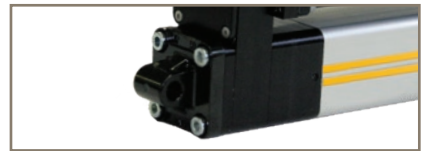

Cylinder rod version

External thread

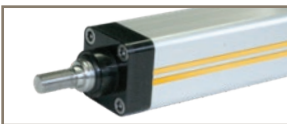

Internal thread



Rod clevis



Spherical rod eye



Force sensor

Joint head with integrated force sensor

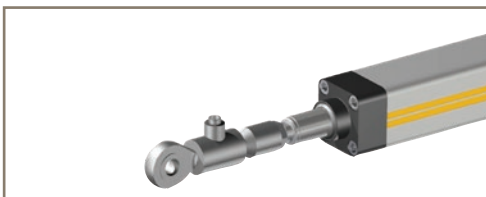

Rod clevis with force sensor

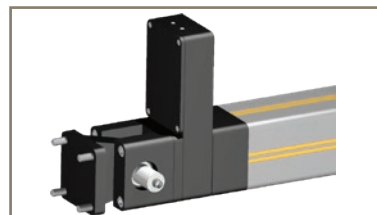

Motor and amplifier

Servo amplifier

For additional information please see our website
www.parker.com/eme

Motors and gears

For additional information on motors please see our website www.parker-eme.com and for gears www.parker.com/eme/gear

Rodless Linear Handling Actuators



HPLA



HLR



OSP-E..BHD



OSP-E..B



OSP-E..SB



OSP-E..ST

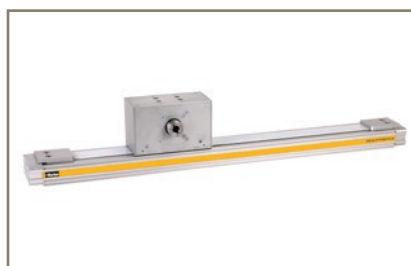

OSP-E..BV

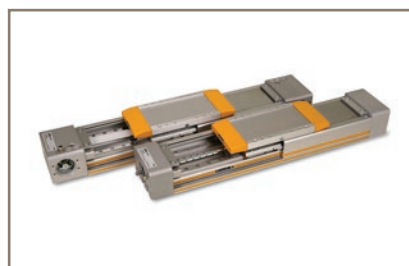

HMR

HPLA - Linear Actuator with Plastic-Sheathed Rollers

For guiding, moving and positioning, even over long travels, we offer the HPLA linear actuator:

- Travels up to 20 meters
- High speeds up to 5 m/s
- High payloads up to 1600 kg
- Nominal drive torque up to 244 Nm
- Nominal thrust force up to 5500 N
- Repeatability up to ± 0.05 mm
- High mechanic efficiency



Specifications

Frame sizes		HPLA 080		HPLA 120		HPLA 180	
Roller guiding system		Plastic	Steel	Plastic	Steel	Plastic	Steel
Weight of base unit without stroke							
HPLA with standard carriage	[kg]	6.0	6.6	18.6	19.8	49.8	53.4
HPLA with steel strip cover	[kg]	6.8	7.5	20.2	21.6	57.2	61.6
HPLA with extended carriage	[kg]	7.8	8.6	23.5	25.2	67.4	72.6
HPLA with steel strip cover	[kg]	8.6	9.5	25.2	27.1	74.8	80.9
Weight of standard carriage & load attachment plate	[kg]	1.5	1.6	5.5	5.7	11.4	11.8
HPLA with steel strip cover	[kg]	1.7	1.8	5.8	6.0	12.3	12.6
Weight of extended carriage & load attachment plate	[kg]	2.4	2.6	8.5	8.9	20.3	21.0
HPLA with steel strip cover	[kg]	2.6	2.8	8.8	9.2	21.1	21.8
Additional weight per meter of stroke	[kg/m]	6.0	7.2	13.5	15.4	29.2	33.4
Weight with steel strip cover	[kg/m]	6.1	7.3	13.7	15.5	29.4	33.6
Travel lengths and speeds							
Max. travel speed	[m/s]	5.0					
Max. acceleration	[m/s ²]	10.0					
Max. travel path (standard carriage)	[mm]	5610	5590	9560	9530	9440	9400
ditto with steel strip cover	[mm]	5540	5520	9470	9440	9240	9200
Max. travel path (extended carriage)	[mm]	5460	5440	9360	9330	9140	9100
ditto with steel strip cover	[mm]	5390	5370	9270	9240	8940	8900
Overall dimensions and physical data of guiding profile							
Section	[mm]	80 x 80		120 x 120		180 x 180	
Forces and torques							
max. drive torque	[Nm]	32		96		365	
max. Thrust force	[N]	1114		2234		5457	
Repeatability up to 3 m ⁽¹⁾	[mm]	± 0.05		± 0.05		± 0.05	
Repeatability from 3 m ⁽¹⁾	[mm]	± 0.1		± 0.1		± 0.1	
Toothed pulley and toothed belt data							
Travel distance per revolution	[mm/U]	180		270		420	
Number of teeth of pulley		18		27		21	
Toothed belt width / pitch	[mm]	25/10		32/10		56/20	

⁽¹⁾ at a constant ambient and operating temperature

Dimensions

HPLA without steel strip cover

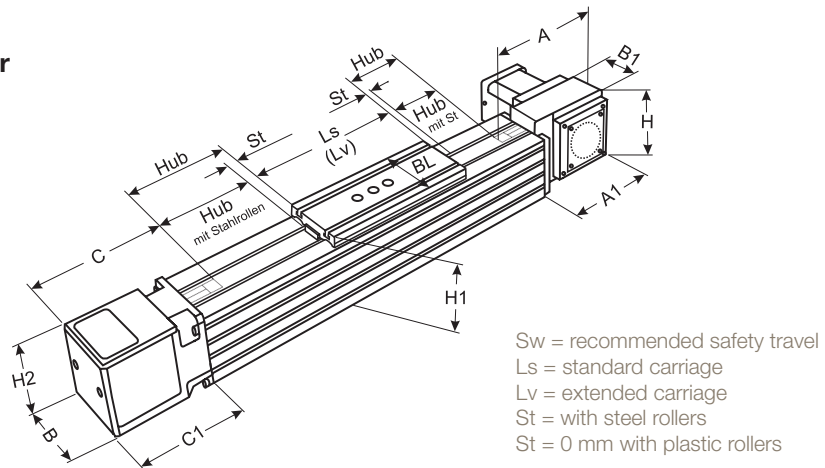

HPLA with toothed belt without steel strip cover

	B	B1	BL	H	H1	H2	A1	A	C	C1	Ls	Lv	St
HPLA 80	80	46	76	100	100	80	144	164	128	108	250	400	10
HPLA 120	120	60	110	135	143	120	185	205	160	140	300	500	13
HPLA 180	180	95	170	213	215	180	265	293	263	235	400	700	20

HPLA with steel strip cover

The optional steel strip cover is perfectly integrated into the linear actuator design and protects timing belt, rollers and the running surfaces of the profile reliably from contamination (protection class IP30).

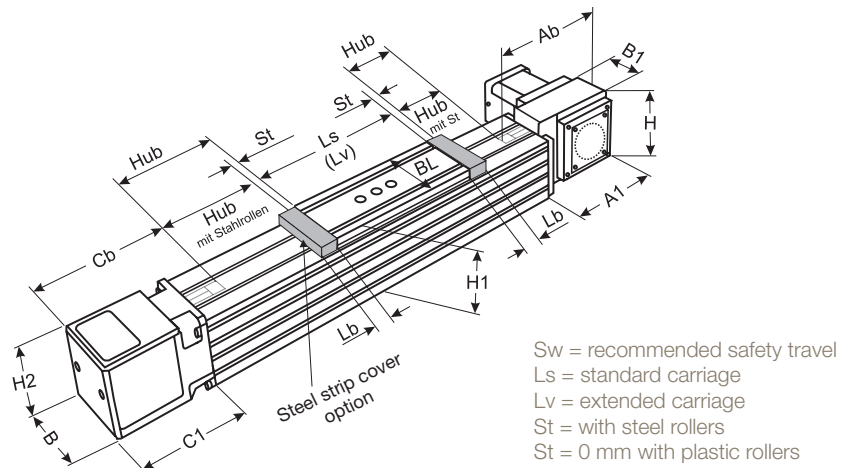

HPLA with toothed belt and steel strip cover

	B	B1	BL	H	H1	H2	A1	Ab	Cb	C1	Ls	Lv	Lb	St
HPLA 80	80	46	76	100	100	80	144	199	163	108	250	400	40	10
HPLA 120	120	60	110	143	143	120	185	250	205	140	300	500	50	13
HPLA 180	180	95	170	215	215	180	265	393	363	235	400	700	100	20

Advantages of plastic roller guiding:

- clean operation, as the travel surface is free of lubricants
- low maintenance

Advantages of steel roller guiding on an integrated steel strip:

- high load bearing capacity
- high stiffness

Accessories for Toothed Belt Actuators

Assembly angle plate isosceles

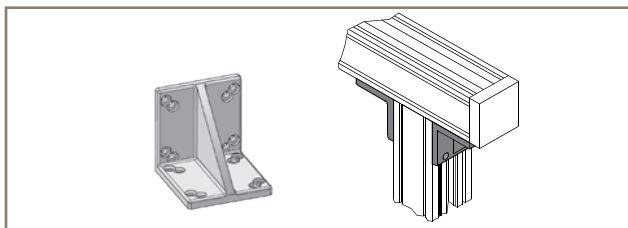

Assembly angle plate scalene

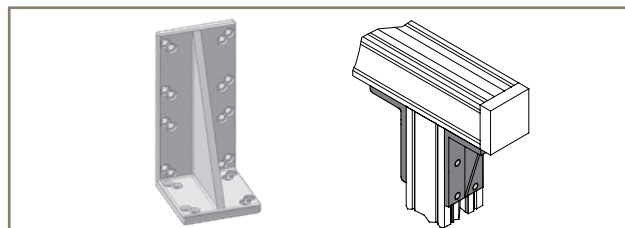

The assembly angle plates are used to connect linear actuators to the basic structure (as support, you may use a Parker profile), or with your construction elements.

Toe Clamp

The toe clamps are used in conjunction with the standard load attachment plate to rapidly install and attach various combinations of linear actuators.

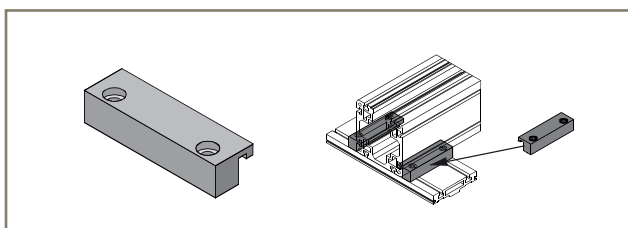

External stop buffer

The external stop buffer is mounted in the grooves of the profile and can be adjusted infinitely.

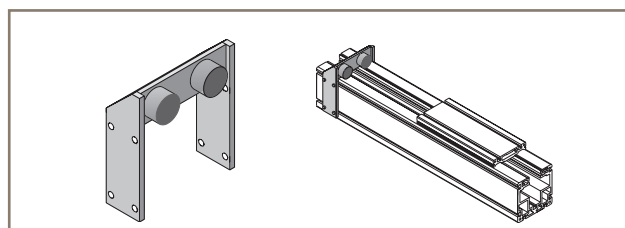

T-Nuts and bolts

The T nuts and bolts can be used to attach other components in the T-slots of the profile, or on the upper side of the load attachment plate.

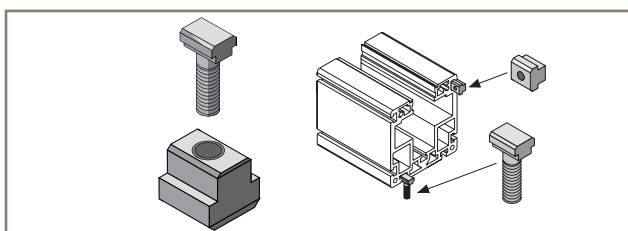

Intermediate shaft bearing for double actuators

The intermediate shaft bearing is used to support the connection shaft of a double actuator in the event of a long axis distance. The intermediate shaft bearing must be used if the critical rotational speed is exceeded with the double actuator connection shaft.

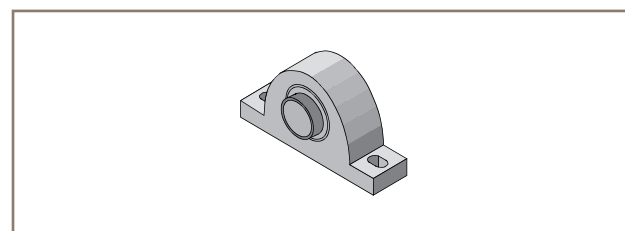

Longitudinal flanges

The working stroke can be more than doubled when using the flange plates. A longitudinal flange is required if the travel path exceeds the profile length.

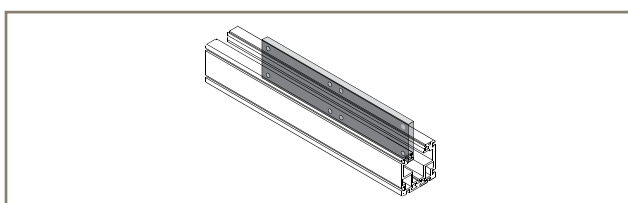

Tripping plate

The tripping plate is suitable for all standard load flange plates.

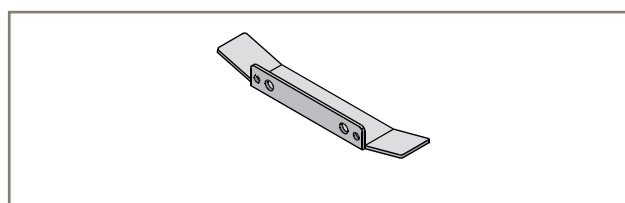

Mechanical limit switch

Switching button as per DIN EN50047. The contacts satisfy the safety requirements by forced opening.

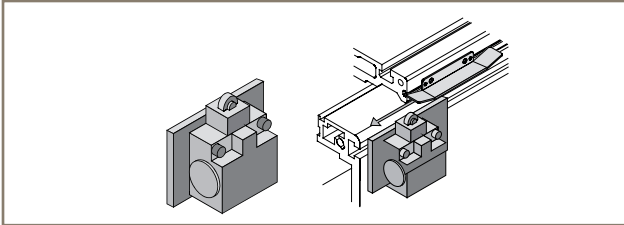

Electrical limit switches

The sensor is activated by a tripping plate on the side on the flange plate.

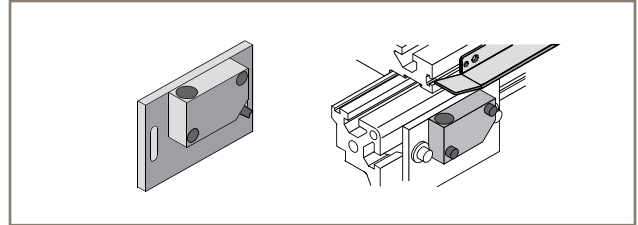

Linear Encoder

The use of a linear encoder increases the static position stiffness of the linear actuator as well as the control properties and positioning accuracy. An additional cable carrier is required due to the moving sensor.

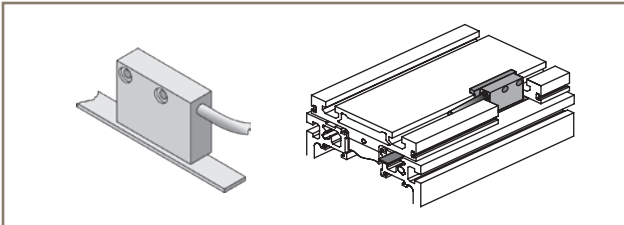

Cable carrier

A cable carrier is needed when making power connections to moving elements. Use only electrical cables which are suitable for use in cable carriers.

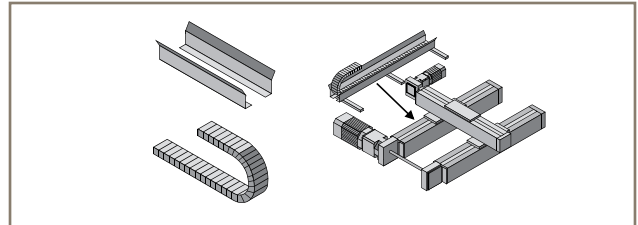

Motor and amplifier

Servo amplifier

For additional information please see our product catalog 192-490123 or our website www.parker.com/eme

Motors and gears

For additional information on motors please see our website www.parker-eme.com/sm and for gears www.parker.com/eme/gear

Other accessories / software

DimAxes

Dimensioning tool for Parker linear actuators, for PC from Windows version 95
Download free of charge from:
<http://www.parker-eme.com/dimaxes>

Belt tension measuring device RSM

For accurately setting the toothed belt tension.



HLR - High Load Rodless Linear Actuator

Overview

Description

HLR is a linear actuator specially designed for the use in OEM applications.

The HLR is a belt driven/ linear guided drive system offering a very high load capacity with an extremely small form factor.

Its compact outer dimensions and a variety of stroke steps make it ideal for a wide range of automation applications.

With its technical data, the HLR family meets the requirements in industrial applications.

Combined with a wide choice of accessories it offers a very quick and easy way to build multi-axis solutions.

The predefined drive trains simplify the sizing and selection process and reduce development time.

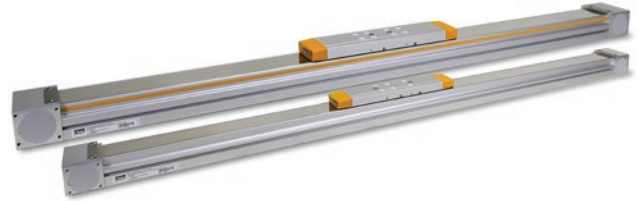

Features

- Compact outside dimensions of 69 x 64 mm and 82 x 76.5 mm
- Rigid aluminum extrusion profile for self-supporting solutions
- High load capacity up to 3847 N (based on a theoretical lifetime of 8.000 km)
- High thrust force up to 900 N
- Motor can be mounted on four sides for highest flexibility
- Acceleration up to 50 m/s²
- Velocity up to 5 m/s
- Last generation linear guide and timing belt for minimised noise emission
- Stainless steel cover as standard for the use in harsh environment
- Easy accessible lubrication bore for reduced maintenance effort
- Extreme straight movement over the complete stroke for building up reliable multi-axis solutions
- High repeatability for highest customer requirements.

Technical Characteristics - Overview

Actuator size	HLR070	HLR080
Drive	Belt drive	
Guiding System	Linear guide	
Width x Height [mm]	69x64	82x76.5
Max. normal load Fz [N]	3847	
Max. thrust force Fx [N]	500	900
Repeatability [mm]	±0.05	
Max. velocity [m/s]	5	
Max. acceleration [m/s ²]	50	
Max. travel length [mm]	2500	3500
Distance [mm/rev]	105	125
Conformity	2011/65/EG: ROHS compliant	
	 RoHS	
Protection class	IP40	

Application

- Material handling and feed systems
- Packaging machines
- General-purpose applications

Product design

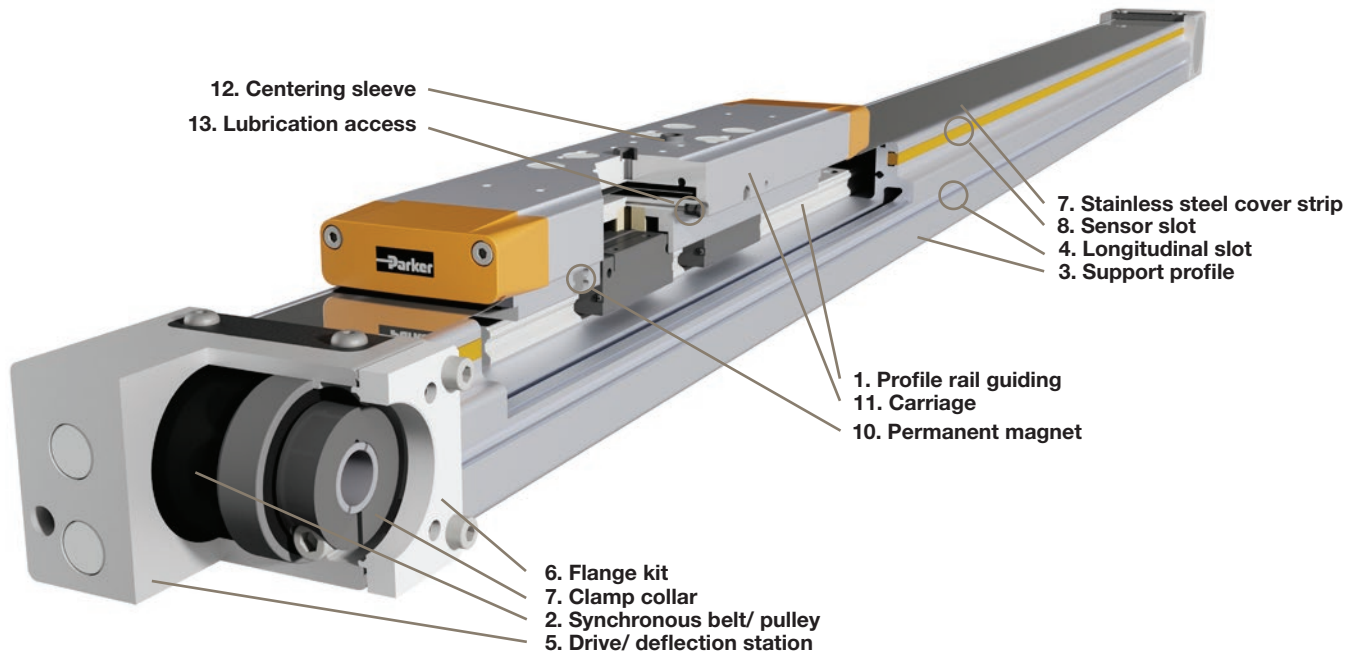

Profile rail guiding (1)

The integrated square rail guide ensures precise and backlash-free linear motion with constant running characteristics and simultaneously high load capacity and travel speed. In conjunction with the synchronous belt (2) and the synchronized pulleys, high feed forces, high repeatability and smoothness are achieved.

Support profile (3)

A lightweight, compact and self-supporting aluminium profile with one longitudinal groove (4) at each side and two at the bottom, which can be used for mounting the linear actuator or other mechanical components.

Drive/ deflection stations (5)

The symmetrically designed drive and deflection stations allow flexible mounting of the drive on each side of the linear actuator. With the optionally available flange kits (6), the drive can be moved to the other station or side at any time by the customer.

The clamping point (7) integrated directly in the drive station enables a direct and very compact connection of the drive to the linear actuator.

Stainless steel cover strip (8)

The stainless steel cover embedded in the support profile is reliably held in place by the magnetic strips integrated in the carrier profile and protects the internal guide against coarse contamination from the outside.

Sensor slot (9)

The sensor slots integrated in the profile on both sides enable the integration of several proximity sensors. These can be attached directly to the support profile at any position and without protruding edges. The sensors are actuated by the permanent magnets (10) integrated in the carriage on both sides. The cables of the sensors can be routed along the linear actuator with the aid of the yellow cover strips.

Carriage (11)

The carriage is available in two standard lengths for each frame size and has several mounting threads for fastening loads. In conjunction with the optionally available toe clamps, the mounting threads allow a cost-effective realisation of a multi-axis system.

The centering sleeves (12) integrated as standard in the carriage allow fast and precise alignment of the load on the carriage.

For relubrication of the internal guide, the carriage has several lubrication accesses (13). These are accessible from both sides of the carriage, making maintenance easier.

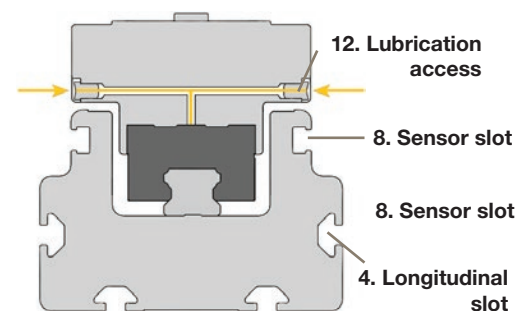

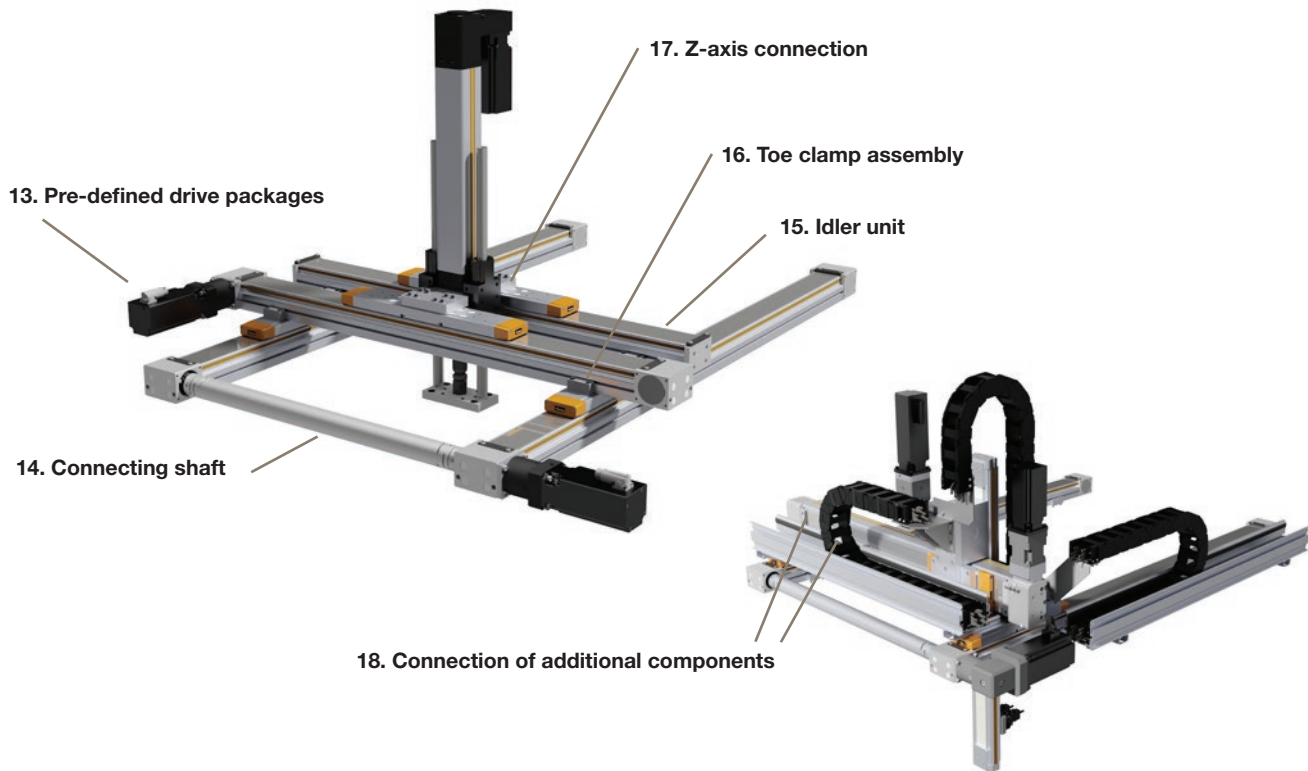

In addition to the two sizes of HLR linear actuators, Parker offers an accessory package not only for single-axis applications, but also for complete double or multi-axis systems.

Pre-defined drive packages (13)

Parker Hannifin also offers the complete drive and control packages for a wide range of applications to match the HLR linear actuators. By using the predefined drive packages, consisting of linear actuator, motor, gearbox and servocontroller, a complete drive train can be quickly selected for the desired application.

Double axis applications

The connecting shaft (14) ensures synchronous and very rigid transmission of the drive torque to a second HLE Linear actuator arranged in parallel. This makes dual axis applications very simple and cost-effective to implement. The connecting shaft is optionally available in different lengths, which allows different center distances to be realized.

For very short centre distances or pure support axes, there is the option of a non-driven, idler axis (15). Here the connecting shaft can be

dispensed with and the load can be mounted directly on the carriage of the driven and the idler axes.

Toe clamp assembly (16)

Toe clamps in different lengths are available for mounting the HLR linear actuators. These grip into the longitudinal slots in the profile and offer a quick and convenient method of fastening. Alternatively, the longitudinal slots in the support profile and slot nuts can also be used. With the toe clamps, one or two cross beams can be fastened directly to the carriage of the HLR linear actuators. This means that no additional connection plates are required and the overall height of the multi-axis system is minimised.

Z-axis connection (17)

With the optionally available mounting plates ETH and ETT can be mounted as z-axis in sizes 032 and 050 as well as the OSP-E20BV directly on the carriage of the HLR linear actuators.

The ETH electric thrust cylinders can also be connected with parallel guidance.

Connection of additional components (18)

Connection of further actuators and energy chains, grippers, etc. is easily possible by the customer by means of the longitudinal slots in the support profile or via the mounting threads in the carriage.

Technical Characteristics

Axis size		HLR070	HLR080
Drive type		Toothed belt drive	
Guiding System		Square rail guide	

Principle dimensions

Axis cross section incl. carriage (width x height)	[mm ²]	69 x 64	82 x 76.5
Max. stroke ¹⁾	[mm]	2500	3500
Carriage A (Standard)	[mm]	372	458
Carriage B (Extended)	[mm]	412	510
Zero stroke with carriage A	[mm]	262	330
Zero stroke with carriage B	[mm]	302	382

Velocity & acceleration

Max. travel speed	[m/s]	5	
Max. acceleration	[m/s ²]	50	

Loads & life times ²⁾

Max. drive torque	[Nm]	8.3	18
Idling torque M_0 ³⁾	[Nm]	0.35	0.55
Max. Thrust force $F_{x,max}$ ⁴⁾	[N]	500	900
Max. Lateral force (Carriage A / Carriage B) $F_{y,max}$	[N]	2 628 / 3 847	3847
Max. load force (carriage A / carriage B) $F_{z,max}$	[N]	2 628 / 3 847	
Max. Tilting torque (carriage A / carriage B) $M_{x,max}$	[Nm]	21 / 30	30
Max. pitching torque (Carriage A / Carriage B) $M_{y,max}$	[Nm]	80 / 164	164 / 262
Max. Yaw torque (Carriage A / Carriage B) $M_{z,max}$	[Nm]	80 / 164	164 / 262

Pulley data

Effective circular diameter	[mm]	33.4	39.8
Feed constant per revolution	[mm]	105	125

Weights

Zero stroke weight with carriage A	[kg]	3.3	5.6
Zero stroke weight with carriage B	[kg]	3.6	5.9
Weight of additional length/ stroke (without carriage)	[kg/m]	4.8	6.6
Zero stroke weight of idler axis with carriage A	[kg]	2.3	3.8
Zero stroke weight of idler axis with carriage B	[kg]	2.7	4.3
Weight of additional length/ stroke of idler axis	[kg/m]	4.6	6.3

Accuracy

Repeatability (according to ISO 230-2)	[mm]	±0.05	±0.05
--	------	-------	-------

Area moment of inertia

Area moment of inertia	[10 ⁴ mm ⁴]	15.7	35.1
------------------------	------------------------------------	------	------

Ambient conditions

Ambient temperature	[°C]	-10...+40	
Storage temperature	[°C]	-20...+40	
Humidity (no condensation)		0...95%	
Protection class		IP40	

Mass moment of inertia relative to the drive shaft

Zero stroke with carriage A	[kgmm ²]	314	752
Zero stroke with carriage B	[kgmm ²]	372	829
Additional length/ stroke (without carriage)	[kgmm ² /m]	53	113
Idler axis with carriage A (stroke independent)	[kgmm ²]	240	554
Idler axis with carriage B (stroke independent)	[kgmm ²]	296	625

- ¹⁾ Min. stroke = 100 mm. Available standard strokes see order code
²⁾ Based on a theoretical lifetime of 8.000 km under ideal conditions
³⁾ Relative to the velocity of 100mm/s with tolerance +/-10%
⁴⁾ Thrust force dependent on travel speed, see diagram2

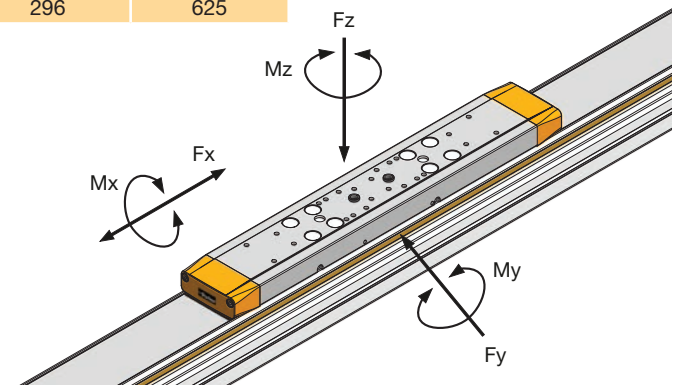

Dimensions

Main dimensions

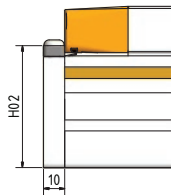
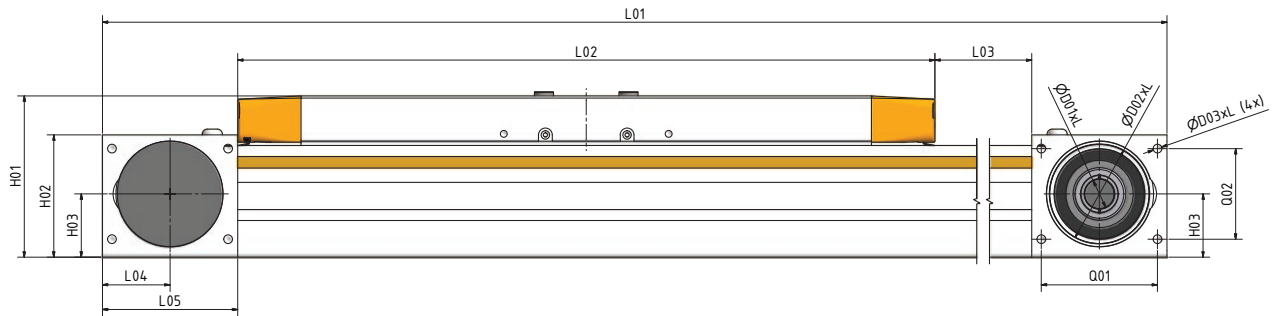

Idler unit ¹⁾

Frame size		HLR070	HLR080
L01	[mm]	L02 + 2 x L05 + stroke	
L02 (carriage A / B)	[mm]	262 / 302	330 / 382
L03	[mm]	Stroke	
L04	[mm]	28	32
L05	[mm]	55	64
H01	[mm]	64	76.5
H02	[mm]	49.3	58
H03	[mm]	22	30
H04	[mm]	20	
H05	[mm]	28.3	35.5
H06	[mm]	²⁾	45
H07	[mm]	44.3	53
B01	[mm]	69	82
B02	[mm]	48.2	63.2
B03	[mm]	30.4	42
B04	[mm]	40	
B05	[mm]	49.8	63.6
B06	[mm]	67	80
Q01	[mm]	42	55
Q02	[mm]	35	43
D01xL	[mm]	10H7 x 10..28	14H7 x 13..34
D02xL	[mm]	40 x 3	47 x 3
D03xL	[mm]	M4 x 12	M5 x 8

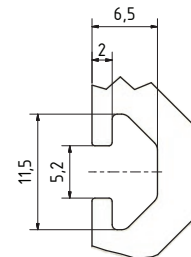
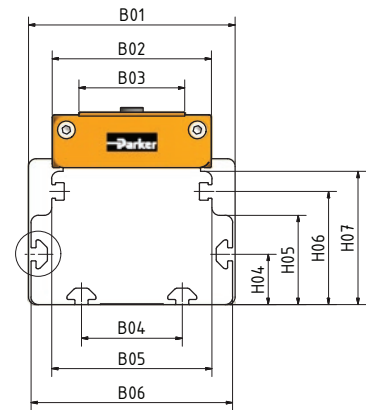

Dimensions in [mm]

¹⁾ Idler axis with end plate on both sides (without drive/ deflection station) for double axis applications with center distances below 200 mm. Example order code for idler axis: **HLR080A1000INNA** (in bold: to be selected)
²⁾ HLR070 has no separate limit switch slot. The limit switches can be mounted in the T-slot.

HLR080 carriage A (short)

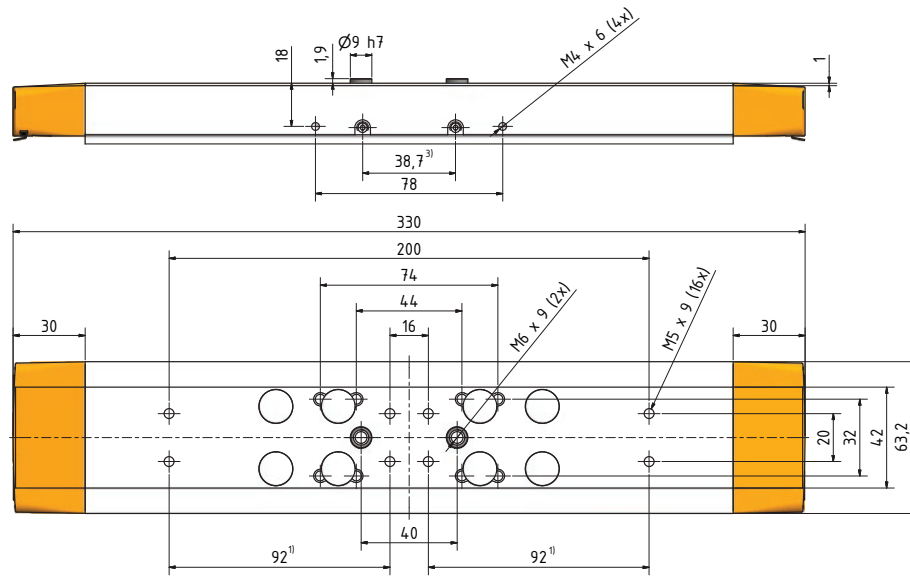

Dimensions in [mm]

HLR080 carriage B (long)

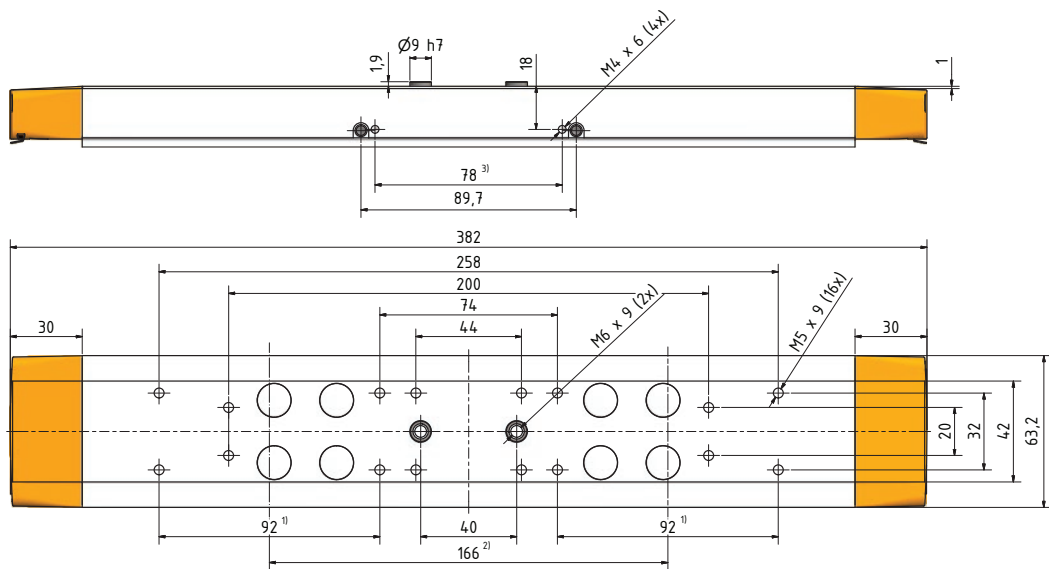

Dimensions in [mm]

- ¹⁾ Distance for mounting a cross axis (HLR080) direct to the carriage by toe clamps
- ²⁾ Axle distance of double axis suitable for the cross beam for the connection of a Z-axis.
- ³⁾ Lubrication nipples on both sides of the carriage plate

OSP-E..BHD - Belt Actuator with Integrated Ball Bearing

Standard Versions:

- Belt Actuator with integrated Ball Bearing Guide
- Drive shaft with clamp shaft or plain shaft
- Choice of motor mounting side
- Dovetail profile for mounting of accessories and the actuator itself

Options:

- Tandem version for higher moments
- Bi-parting version for synchronised movements
- Drive shaft with
 - clamp shaft and plain shaft
 - hollow shaft with keyway
- Special drive shaft versions on request

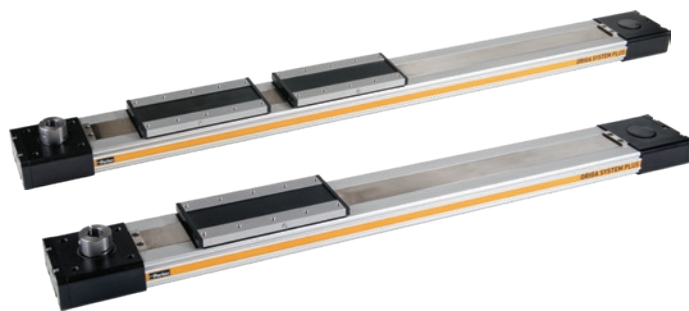

Installation Instructions

Use the threaded holes in the end cap for mounting the actuator.

Check if profile mountings are needed using the maximum allowable unsupported length graph.

At least one end cap must be secured to prevent axial sliding when profile mountings are used.

Characteristics	Description
Series	OSP-E..BHD
Mounting	See drawings
Ambient temperature range	-30 °C to +80 °C
Installation	In any position
Encapsulation class	IP 54
Material	
Slotted profile	Extruded anodized aluminium
Belt	Steel-corded polyurethane
Pulley	Aluminium
Guide	Ball bearing guide
Guide rail	Hardened steel rail with high precision, accuracy class N
Guide carrier	Steel carrier with integrated wiper system, grease nipples, preloaded 0.02 x C, accuracy class H
Steel band	Hardened, corrosion resistant steel
Screws, nuts	Zinc plated steel
Mountings	Zinc plated steel and aluminium

Weight (mass) and Inertia

Series	Weight (mass)[kg]			Inertia [$\times 10^{-6}$ kgm ²]		
	At stroke 0 m	Add per metre stroke	Moving mass	At stroke 0 m	Add per metre stroke	per kg mass
OSP-E20BHD	2.8	4	0.8	280	41	413
OSP-E25BHD	4.3	4.5	1.5	1229	227	821
OSP-E32BHD	8.8	7.8	2.6	3945	496	1459
OSP-E50BHD	26	17	7.8	25678	1738	3103
OSP-E20BHD*	4.3	4	1.5	540	41	413
OSP-E25BHD*	6.7	4.5	2.8	2353	227	821
OSP-E32BHD*	13.5	7.8	5.2	7733	496	1459
OSP-E50BHD*	40	17	15	49180	1738	3103

* Version: Tandem and Bi-parting (Option)

Maintenance

Depending on operating conditions, inspection of the actuator is recommended after 12 months or 3000 km operation. Please refer to the operating instructions supplied with the actuator.

First service start-up

The maximum values specified in the technical data sheet for the different products must not be exceeded. Before taking the actuator as a machine into service, the user must ensure the adherence to the machine directive.

Sizing Performance Overview

Maximum Loadings

Sizing of Actuator

The following steps are recommended for selection :

1. Determination of the lever arm length l_x , l_y and l_z from m_e to the centre axis of the actuator.
2. Calculation of the load F_x or F_y to the carrier caused by m_e
 $F = m_e \cdot g$
3. Calculation of the static and dynamic force F_A which must be transmitted by the belt.

$$F_{A(\text{horizontal})} = F_a + F_0$$

$$= m_g \cdot a + M_0 \cdot 2\pi / U_{ZR}$$

$$F_{A(\text{vertical})} = F_g + F_a + F_0$$

$$= m_g \cdot g + m_g \cdot a + M_0 \cdot 2\pi / U_{ZR}$$
4. Calculation of all static and dynamic bending moments M_x , M_y and M_z which occur in the application
 $M = F \cdot l$
5. Selection of maximum permissible loads via Table T3.
6. Calculation and checking of the combined load, which must not be higher than 1.
7. Checking of the maximum torque that occurs at the drive shaft in Table T2.
8. Checking of the required action force F_A with the permissible load value from Table T1.

For motor sizing, the effective torque must be determined, taking into account the cycle time.

Legend

- l = distance of a mass in the x-, y- and z-direction from the guide [m]
- m_e = external moved mass [kg]
- m_{LA} = moved mass of actuator [kg]
- m_g = total moved mass ($m_e + m_{LA}$) [kg]
- $F_{x/y}$ = load exerted on the carrier in dependence of the installation position [N]
- F_A = action force [N]
- M_0 = no-load torque [Nm]
- U_{ZR} = circumference of the pulley (linear movement per revolution) [m]
- g = gravity [m/s²]
- a_{max} = maximum acceleration [m/s²]

Performance Overview

Characteristics	Unit	Description				
Series		OSP-E20BHD	OSP-E25BHD	OSP-E32BHD	OSP-E50BHD	
Max. speed	[m/s]	3 ¹⁾	5 ¹⁾	5 ¹⁾	5 ¹⁾	
Linear motion per revolution of drive shaft	[mm]	125	180	240	350	
Max. rpm on drive shaft	[min ⁻¹]	2000	1700	1250	860	
Max. effective Action force F_A at speed	< 1 m/s:	[N]	550	1070	1870	3120
	1-3 m/s:	[N]	450	890	1560	2660
	> 3 m/s:	[N]	–	550	1030	1940
No-load torque	[Nm]	0.6	1.2	2.2	3.2	
Max. acceleration/deceleration	[m/s ²]	50	50	50	50	
Repeatability	[mm/m]	±0.05	±0.05	±0.05	±0.05	
Max. standard stroke length	[mm]	5760 ²⁾	5700 ²⁾	5600 ²⁾	5500 ²⁾	

¹⁾ up to 10 m/s on request
²⁾ longer strokes on request

Maximum Permissible Torque on Drive Shaft Speed / Stroke

OSP-E20BHD				OSP-E25BHD				OSP-E32BHD				OSP-E50BHD			
Speed [m/s]	Torque [Nm]	Stroke [m]	Torque [Nm]	Speed [m/s]	Torque [Nm]	Stroke [m]	Torque [Nm]	Speed [m/s]	Torque [Nm]	Stroke [m]	Torque [Nm]	Speed [m/s]	Torque [Nm]	Stroke [m]	Torque [Nm]
1	11	1	11	1	31	1	31	1	71	1	71	1	174	1	174
2	10	2	11	2	28	2	31	2	65	2	71	2	159	2	174
3	9	3	8	3	25	3	31	3	59	3	60	3	153	3	138
4		4	7	4	23	4	25	4	56	4	47	4	143	4	108
5		5	5	5	22	5	21	5	52	5	38	5	135	5	89

Important:

The maximum permissible torque on the drive shaft is the lowest value of the speed or stroke-dependent torque value.

Example above:

OSP-E25BHD, stroke 5 m, required speed 3 m/s from table T2
speed 3 m/s gives 25 Nm and stroke 5 m gives 21 Nm. Max. torque for this application is 21 Nm.

Maximum Permissible Loads

Series	Max. applied load		Max. moments [Nm]		
	Fy[N]	Fz[N]	Mx	My	Mz
OSP-E20BHD	1600	1600	21	150	150
OSP-E25BHD	2000	3000	50	500	500
OSP-E32BHD	5000	10000	120	1000	1400
OSP-E50BHD	12000	15000	180	1800	2500

Options and Accessories

OSP-E..BHD Belt actuator with integrated guide

STANDARD VERSIONS OSP-E..BHD

Standard carrier with integrated guide and magnets for contactless position sensing. Dovetail profile for mounting of accessories and the actuator itself.

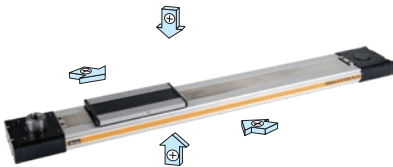

DRIVE SHAFT WITH CLAMP SHAFT



DRIVE SHAFT WITH PLAIN SHAFT



ACTUATING DIRECTION
 Important in parallel operations, e.g. with intermediate drive shaft

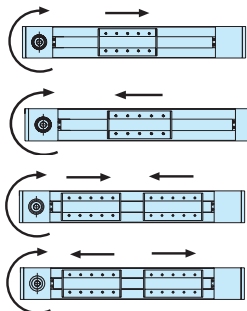

Standard

Standard -
 Bi-Parting
 Version

OPTIONS

TANDEM
 For higher moment support.

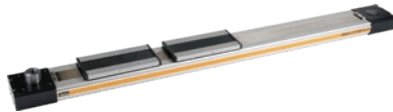

BI-PARTING VERSION
 For perfectly synchronised bi-parting movements.

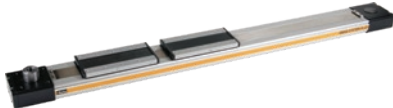

DRIVE SHAFT WITH CLAMP SHAFT AND PLAIN SHAFT
 For connections with intermediate drive shaft

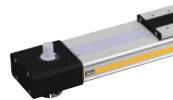

HOLLOW SHAFT WITH KEYWAY
 For close coupling of motors and external gears.

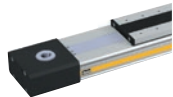

ACCESSORIES

MOTOR MOUNTINGS



END CAP MOUNTING
 For mounting the actuators on the end cap.

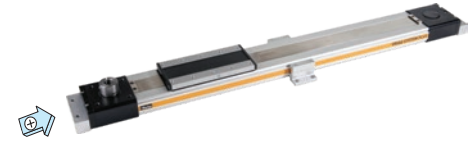

PROFILE MOUNTING
 For supporting long actuators or mounting the actuators on dovetail grooves.

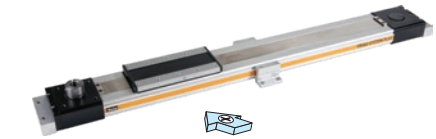

MAGNETIC SWITCHES TYPE RS AND ES
 For contactless position sensing of end stop and intermediate carrier positions.

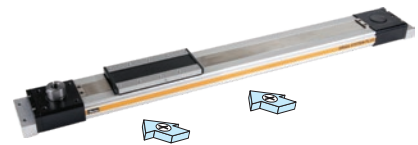

MULTI-AXIS SYSTEMS
 For modular assembly of actuators up to multi-axis systems.

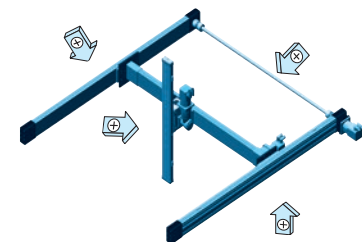

OSP-E..B - Belt Actuator with Internal Plain Bearing Guide



Standard Versions:

- Standard carrier with internal plain bearing guide
- Dovetail profile for mounting of accessories and the actuator itself
- Position of drive shafts

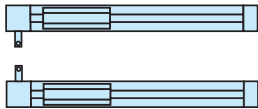

Options:

- Tandem version
- Bi-parting version for synchronized movements
- Drive shaft with double plain shaft

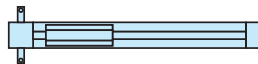

Installation Instructions

Use the threaded holes in the end cap for mounting the actuator. See if Profile Mountings are needed using the maximum allowable unsupported length graph. At least one end cap must be secured to prevent axial sliding when profile mounting is used. When the actuator is moving an externally guided load, the compensation must be used.

The actuators can be fitted with the standard carrier mounting facing in any direction.

To prevent contamination such as fluid ingress, the actuator should be fitted with its sealing band facing downwards.

The inversion mounting can be fitted to transfer the driving force to the opposite side.

Characteristics	Description
Series	OSP-E..B
Mounting	See drawings
Ambient temperature range	-30 °C to +80 °C
Installation	See table
Encapsulation class	IP 54
Material	
Slotted Profile	Extruded anodized aluminium
Belt	Steel-corded polyurethane
Pulley	Aluminium
Guide bearings	Low friction plastic
Sealing band	Hardened corrosion resistant steel
Screws, nuts	Zinc plated steel
Mountings	Zinc plated steel and aluminium

Weight (mass) and Inertia

Series	at stroke 0 m	Weight (mass) [kg]		Inertia [$\times 10^{-6}$ kgm ²]	
		ad per meter stroke	moving mass	at stroke 0 m	ad per meter stroke
OSP-E25B	0.9	1.6	0.2	25	6.6
OSP-E32B	1.9	3.2	0.4	43	10
OSP-E50B	5.2	6.2	1.0	312	45
OSP-E25B*	1.2	1.6	0.5	48	6.6
OSP-E32B*	2.3	3.2	0.8	83	10
OSP-E50B*	6.3	6.2	2.1	585	45

* Version: Tandem and Bi-parting (Option)

Maintenance

All moving parts are long-term lubricated for a normal operational environment. Parker Origa recommends a check and lubrication of the actuator, and if necessary a change of the belt and wear parts, after an operation time of 12 months of operation or 3 000 km travel of distance. Additional greasing is easily done by using nipples in the slotted profile. Please refer to the operating instructions supplied with the actuator.

First service start-up

The maximum values specified in the technical data sheet for the different products must not be exceeded. Before taking the actuator as a machine into service, the user must ensure the adherence to the machine directive.

Sizing Performance Overview

Maximum Loadings

Sizing of Actuator

The following steps are recommended for selection :

1. Required acceleration,
2. Required torque is shown on page 332
3. Check that maximum values in the table 3 are not exceeded
4. Drive shaft by using table T2. (Pay attention to note under table) If value is lower than required, overview the moving profile or select if possible a bigger unit.
5. Before sizing and specifying the motor, the average torque must be calculated using the cycle time of the application.
6. Check that the maximum allowable unsupported length is not exceeded.

Performance Overview

Characteristics	Unit	Description			
Size		OSP-E25B	OSP-E32B	OSP-E50B	
Max. speed	[m/s]	2	3	5	
Linear motion per revolution, drive shaft	[mm]	60	60	100	
Max. rpm drive shaft	[min ⁻¹]	2 000	3 000	3 000	
Max. effective action force F_A at speed	< 1 m/s:	[N]	50	150	425
	1 - 2 m/s:	[N]	50	120	375
	> 2 m/s:	[N]	–	100	300
No-load torque	[Nm]	0.4	0.5	0.6	
Max. acceleration/deceleration	[m/s ²]	10	10	10	
Repeatability	[mm/m]	±0.05	±0.05	±0.05	
Max. stroke length OSP-E..B	[mm]	3000	5000	5000	
Max. stroke length OSP-E..B*	[mm]	2 x 1500	2 x 2500	2 x 2500	

* Bi-parting version

Maximum Permissible Torque on Drive Shaft Speed / Stroke T2

OSP-E25B				OSP-E32B				OSP-E50B			
Speed [m/s]	Torque [Nm]	Stroke [m]	Torque [Nm]	Speed. [m/s]	Torque [Nm]	Stroke [m]	Torque [Nm]	Speed. [m/s]	Torque [Nm]	Stroke [m]	Torque [Nm]
1	0.9	1	0.9	1	2.3	1	2.3	1	10.0	1	10.0
2	0.9	2	0.9	2	2.0	2	2.3	2	9.5	2	10.0
		3	0.9			3	1.8			3	9.0
3	0.9	3	0.9	3	1.8	4	2.3	3	9.0	4	7.0
						5	1.8			5	6.0

Important:

The maximum permissible torque on the drive shaft is the lowest value of the speed or stroke-dependent torque value.

Example above:

OSP-E32B stroke 2 m, required speed 3 m/s;

From table T2: speed 3 m/s gives 1.8 Nm and stroke 2 m gives 2.3 Nm.

Max. torque for this application is 1.8 Nm.

Loads, Forces and Moments

Combined loads

If the actuator is subjected to several forces, loads and moments at the same time, the maximum load is calculated with the equation shown here.

The maximum permissible loads must not be exceeded.

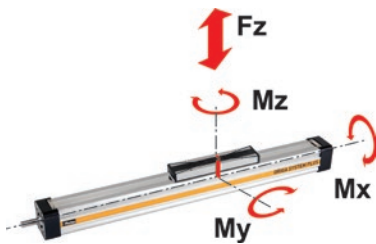

$$M = F \cdot l \text{ [Nm]}$$

$$M_x = M_{x \text{ static}} + M_{x \text{ dynamic}}$$

$$M_y = M_{y \text{ static}} + M_{y \text{ dynamic}}$$

$$M_z = M_{z \text{ static}} + M_{z \text{ dynamic}}$$

The distance l (l_x , l_y , l_z) for calculation of the bending moments relates to the centre axis of the actuator.

Maximum Permissible Loads T3

Size	Max. applied load [N] F_z	Max. moments [Nm]		
		M_x	M_y	M_z
OSP-E25B	500	2	12	8
OSP-E32B	1200	8	25	16
OSP-E50B	3000	16	80	32
OSP-E..B Bi-partional	The maximum load F must be equally distributed among the two carriers			

Equation of Combined Loads

$$\frac{F_z}{F_z \text{ (max)}} + \frac{M_x}{M_x \text{ (max)}} + \frac{M_y}{M_y \text{ (max)}} + \frac{M_z}{M_z \text{ (max)}} \leq 1$$

The total of the loads must not exceed >1 under any circumstances.

Options and Accessories

OSP-E..B

Belt actuator with internal plain bearing guide

STANDARD VERSIONS OSP-E..B

Carrier with internal guidance and magnet packet for contactless position sensing. Dovetail profile for mounting of accessories and the actuator itself.

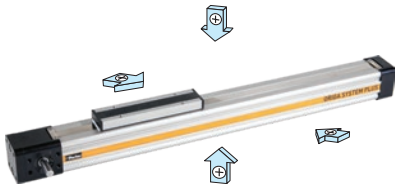

DRIVE SHAFT VERSIONS

- Plain shaft or
- double plain shaft (Option)
e.g. to drive two actuators in parallel.

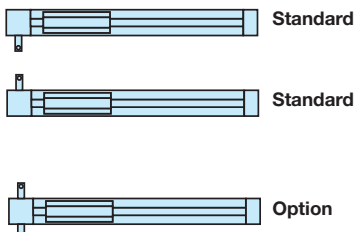

OPTIONS

TANDEM

For higher moment support.



BI-PARTING

For perfectly synchronised bi-parting movements.



ACCESSORIES

MOTOR MOUNTING



END CAP MOUNTING

For end-mounting of the actuator.



PROFILE MOUNTING

For supporting long actuators or mounting the actuator on the dovetail grooves.

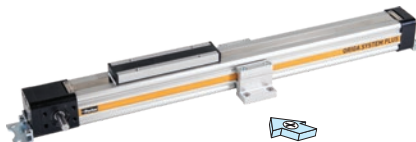

CLEVIS MOUNTING

Carrier with tolerance and parallelism compensation to drive external linear guides.

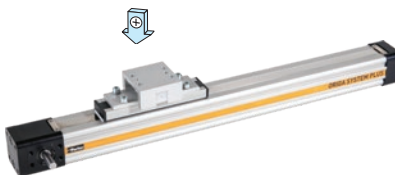

INVERSION MOUNTING

The inversion mounting, mounted on the carrier, transfers the driving force to the opposite side, e.g. for dirty environments.

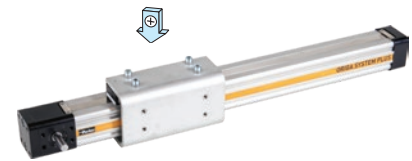

MAGNETIC SWITCHES

SERIES RST AND EST

For contactless position sensing of end stop and intermediate carrier positions.



OSP-E..SB - Ball Screw Actuator with Internal Plain Bearing Guide



Standard Versions:

- Standard carrier with internal plain bearing guide
- Dovetail profile for mounting of accessories and the actuator itself
- Pitches of Ball Screw
 Type OSP-E25 : 5 mm
 Type OSP-E32: 5 , 10 mm
 Type OSP-E50: 5 , 10, 25 mm

Options:

- Tandem version

Installation Instructions

Use the threaded holes in the end cap for mounting the actuator. See if Profile Mountings are needed using the maximum allowable unsupported length graph. At least one end cap must be secured to prevent axial sliding when profile mounting is used.

When the actuator is moving an externally guided load, the compensation must be used.

The actuators can be fitted with the standard carrier mounting facing in any direction.

To prevent contamination such as fluid ingress, the actuator should be fitted with its sealing band facing downwards.

The inversion mounting can be fitted to transfer the driving force to the opposite side.

Characteristics	Description
Series	OSP-E..SB
Ambient temperature range	-20 °C to +80 °C
Installation	In any position
Mounting	See drawing
Encapsulation class	IP 54
Material	
Slotted Profile	Extruded anodized aluminium
Ball screw	Hardened steel
Ball screw nut	Hardened steel
Guide bearings	Low friction plastic
Sealing band	Hardened corrosion resistant steel
Screws, nuts	Zinc plated steel
Mountings	Zinc plated steel and aluminium

Weight (mass) and Inertia

Series	at stroke 0 m	Weight (mass) [kg]		Inertia [$\times 10^{-6}$ kgm ²]	
		ad per meter stroke	moving mass	at stroke 0 m	ad per meter stroke
OSP-E25SB	0.8	2.3	0.2	2.2	11
OSP-E32SB	2.0	4.4	0.4	8.4	32
OSP-E50SB	5.2	9.4	1.2	84.0	225

Maintenance

All moving parts are long-term lubricated for a normal operational environment. Parker Origa recommends a check and lubrication of the actuator, and if necessary a change of the belt and wear parts, after an operation time of 12 months of operation or 3 000 km travel of distance. Please refer to the operating instructions supplied with the actuator.

First service start-up

The maximum values specified in the technical data sheet for the different products must not be exceeded. Before taking the actuator as a machine into service, the user must ensure the adherence to the machine directive.

Sizing Performance Overview

Maximum Loadings

Sizing of Actuator

The following steps are recommended for selection :

1. Recommended maximum acceleration is shown in graphs
2. Required torque is shown in graphs
3. Check that maximum values in the adjacent charts are not exceeded.
4. When sizing and specifying the motor, the RMS-average torque must be calculated using the cycle time of the application.
5. Check that the maximum allowable unsupported length is not exceeded.

Performance Overview

Characteristics	Unit	Description					
		OSP-E25SB	OSP-E32SB			OSP-E50SB	
Series		OSP-E25SB	OSP-E32SB			OSP-E50SB	
Pitch	[mm]	5	5	10	5	10	25
Max. speed	[m/s]	0.25	0.25	0.5	0.25	0.5	1.25
Linear motion per revolution drive shaft	[mm]	5	5	10	5	10	25
Max. rpm, drive shaft	[min ⁻¹]	3 000	3 000			3 000	
Max. effective action force F _A	[N]	250	600	1 500			
Corresponding torque on drive shaft	[Nm]	0.35	0.75	1.3	1.7	3.1	7.3
No-load torque	[Nm]	0.2	0.2	0.3	0.3	0.4	0.5
Max. allowable torque on drive shaft	[Nm]	0.6	1.5	2.8	4.2	7.5	20
Repeatability	[mm/m]	±0.05	±0.05			±0.05	
Max. Standard stroke length	[mm]	1100	2000			3200	

Forces, loads and moments

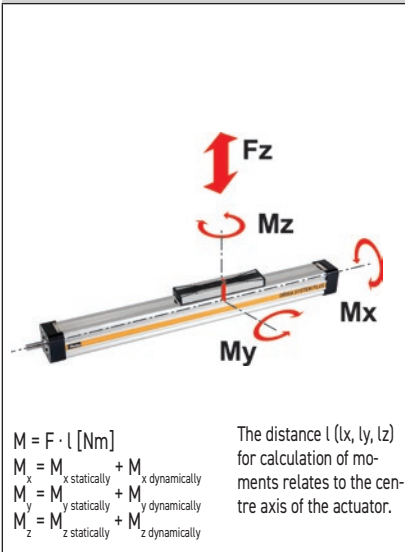

Combined Loads

If the actuator is subjected to several forces, loads and moments at the same time, the maximum load is calculated with the equation shown here. The maximum permissible loads must not be exceeded.

Maximum permissible Loads

Series	Max. applied load [N] Fz	Max. moments [Nm]		
		Mx	My	Mz
OSP-E25SB	500	2	12	8
OSP-E32SB	1200	8	25	16
OSP-E50SB	3000	16	80	32

Equation for combined loads

$$\frac{F_z}{F_z \text{ (max)}} + \frac{M_x}{M_x \text{ (max)}} + \frac{M_y}{M_y \text{ (max)}} + \frac{M_z}{M_z \text{ (max)}} \leq 1$$

The total of loads must not exceed >1 under any circumstances.

OSP-E..ST - Trapezoidal Screw Actuator with Internal Plain Bearing Guide

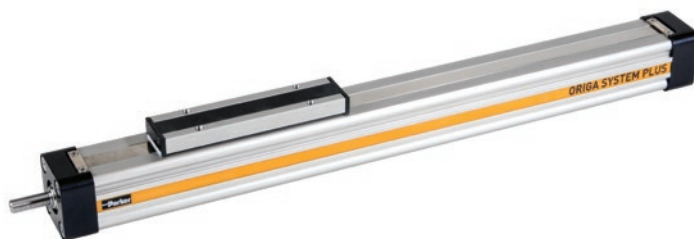

Standard Versions:

- Standard carrier with internal plain bearing guide
- Dovetail profile for mounting of accessories and the actuator itself
- Pitch of Trapezoidal Spindle:
Type OSP-E25ST : 4 mm
Type OSP-E32ST: 4 mm
Type OSP-E50ST: 6 mm

Installation Instructions

Use the threaded holes in the free end cap and a profile mounting close to the motor end for mounting the actuator. See if profile mountings are needed using the maximum permissible unsupported length graph. At least one end cap must be secured to prevent axial sliding when Profile Mounting is used. When the actuator is moving an externally guided load, the compensation must be used. The actuators can be fitted with the standard carrier mounting facing in any direction. To prevent contamination such as fluid ingress, the drive should be fitted with its sealing band facing downwards. The inversion mounting can be fitted to transfer the driving force to the opposite side.

Characteristics	Description
Series	OSP-E..ST
Mounting	See drawings
Ambient temperature range	-20 °C to +70 °C
Installation	In any position
Material	
Slotted Profile	Extruded anodized aluminium
Trapezoidal screw	Cold rolled steel
Drive nut	Thermoplastic polyester
Guide bearings	Low friction plastic
Sealing band	Hardened corrosion resistant steel
Screws, nuts	Zinc plated steel
Mountings	Zinc plated steel and aluminium

Weight (mass) and Inertia

Series	Weight (mass) [kg]			Inertia [$\times 10^{-6}$ kgm ²]	
	at stroke 0 m	ad per meter stroke	moving mass	at stroke 0 m	ad per meter stroke
OSP-E25ST	0.9	2.8	0.2	6	30
OSP-E32ST	2.1	5.0	0.5	21.7	81
OSP-E50ST	5.1	10.6	1.3	152	400

Maintenance

All moving parts are long-term lubricated for a normal operational environment. Parker Origa recommends a check and lubrication of the actuator, and if necessary a change of the belt and wear parts, after an operation time of 12 months of operation or 3000 km travel of distance. Please refer to the operating instructions supplied with the drive

First service start-up

The maximum values specified in the technical data sheet for the different products must not be exceeded. Before taking the actuator as a machine into service, the user must ensure the adherence to the machine directive.

Sizing Performance Overview

Maximum Loadings

Sizing of Actuator

The following steps are recommended for selection :

1. Check that maximum values in the table T3 are not exceeded.
2. Check the maximum values in graph are not exceeded.
3. When sizing and specifying the motor, the RMS-average torque must be calculated using the cycle time of the application.
4. Check that the maximum allowable unsupported length is not exceeded

Performance Overview

Characteristics	Unit	Description		
		OSP-E25ST	OSP-E32ST	OSP-E50ST
Size		OSP-E25ST	OSP-E32ST	OSP-E50ST
Pitch	[mm]	4	4	6
Max. speed	[m/s]	0.1	0.1	0.15
Linear motion per revolution drive shaft	[mm]	4	4	6
Max. rpm, drive shaft	[min-1]	1500	1500	1500
Max. effective action force FA	[N]	600	1300	2 500
Corresponding torque on drive shaft	[Nm]	1.35	3.2	8.8
No-load torque	[Nm]	0.3	0.4	0.5
Max. allowable torque on drive shaft	[Nm]	1.55	4.0	9.4
Self-locking force FL1)	[N]	600	1300	2500
Repeatability	[mm/m]	±0.5	±0.5	±0.5
Max. Standard stroke length	[mm]	1100	2000	2500*

¹⁾ Related to screw types Tr 16x4, Tr 20x4, TR30x6

* For strokes longer than 2000 mm in horizontal applications, please contact our customer support.

Forces, loads and moments

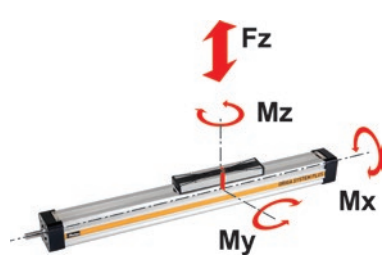

$M = F \cdot l$ [Nm]
 $M_x = M_{x \text{ static}} + M_{x \text{ dynamic}}$
 $M_y = M_{y \text{ static}} + M_{y \text{ dynamic}}$
 $M_z = M_{z \text{ static}} + M_{z \text{ dynamic}}$

The distance l (l_x, l_y, l_z) for calculation of the bending moments relates to the centre axis of the actuator.

Maximum Permissible Loads T3

Size	Max. applied load [N] Fz	Max. moments [Nm]		
		Mx	My	Mz
OSP-E25ST	500	2	24	7
OSP-E32ST	1000	6	65	12
OSP-E50ST	1500	13	155	26

Equation for Combined Loads

$$\frac{F_z}{F_z \text{ (max)}} + \frac{M_x}{M_x \text{ (max)}} + \frac{M_y}{M_y \text{ (max)}} + \frac{M_z}{M_z \text{ (max)}} \leq 1$$

The total of the loads must not exceed >1 under any circumstances.

Combined Loads

If the actuator is subjected to several forces, loads and moments at the same time, the maximum load is calculated with the equation shown here. The maximum permissible loads must not be exceeded.

OSP-E..BV - Vertical Belt Actuator with Integrated Ball Bearing Guide



Standard Versions:

- Vertical belt actuator with integrated ball bearing guide
- Drive shaft with clamp shaft or plain shaft
- Choice of motor mounting side

Options:

- Tandem version for higher moments
- Drive shaft with
 - clamp shaft and plain shaft or double plain shaft
 - hollow shaft with keyway
- Special drive shaft versions on request

Installation Instructions

Make sure that the OSP-E..BV is always operated by motor with holding brake on the actuator side. For the mounting of the external mass to be moved there are threaded holes in the end caps. Before mounting, check the correct centre of gravity distance from the table.

Mount the external mass on the belt fixed end, so that the belt tension can be checked and adjusted at the belt tensioning end without dismantling.

Characteristics	Description
Series	OSP-E..BV
Mounting	See drawings
Ambient temperature range	-30 °C to +80 °C
Installation	Vertical
Encapsulation class	IP 20
Material	
Profile	Extruded anodized aluminium
Belt	Steel-corded polyurethane
Pulley	Aluminium
Guide	Ball bearing guide
Guide rail	Hardened steel rail with high precision, accuracy class N
Guide carrier preloaded 0.08 x C, accuracy class N	Steel carrier with integrated wiper system, grease nipples,
Screws, nuts	Zinc plated steel

Weight (mass) and Inertia

Series	Total weight (Mass) [kg]		Moving mass [kg]		Inertia [$\times 10^{-6}$ kgm ²]		
	At stroke 0 m	Actuator head	At stroke 0 m	Add per metre stroke	At Stroke 0 m	Add per metre stroke	Add per kg mass
OSP-E20BV	3.4	1.9	1.6	4.0	486	1144	289
OSP-E25BV	7.7	5.3	2.4	4.4	1695	2668	617
OSP-E20BV*	5.3	2 x 1.9	1.6	4.0	533	1144	289
OSP-E25BV*	13	2 x 5.3	2.4	4.4	1915	2668	617

* Version: Tandem (Option)

Maintenance

Depending on operating conditions, inspection of the actuator is recommended after 12 months or 3000 km operation. Please refer to the operating instructions supplied with the actuator.

First service start-up

The maximum values specified in the technical data sheet for the different products must not be exceeded. Before taking the actuator as a machine into service, the user must ensure the adherence to the machine directive.

Sizing Performance Overview

Maximum Loadings

Sizing of Actuator

The following steps are recommended for selection :

1. Determination of the lever arm length l_x , l_y and l_z from m_e to the centre axis of the actuator.
2. Calculation of the static and dynamic force F_A which must be transmitted by the belt.

$$F_A = F_g + F_a + F_0$$

$$= m_g \cdot g + m_g \cdot a + M_0 \cdot 2\pi / U_{ZR}$$
3. Calculation of all static and dynamic moments M_x , M_y and M_z which occur in the application.

$$M = F \cdot l$$
4. Selection of maximum permissible loads via Table T3.
5. Calculation and checking of the combined load, which must not be higher than 1.
6. Checking of the maximum moment that occurs at the drive shaft in Table T2.
7. Checking of the required action force F_A with the permissible load value from Table T1.

For motor sizing, the effective torque must be determined, taking into account the cycle time.

Legend

- l = distance of a mass in the x-, y- and z-direction from the guide [m]
- m_e = external moved mass [kg]
- m_{LA} = moved mass of actuator [kg]
- m_g = total moved mass ($m_e + m_{LA}$) [kg]
- F_A = action force [N]
- M_0 = no-load torque [Nm]
- U_{ZR} = circumference of the pulley (linear movement per revolution) [m]
- g = gravity [m/s²]
- a_{max} = maximum acceleration [m/s²]

Performance Overview

Characteristics	Unit	Description		
Series		OSP-E20BV	OSP-E25BV	
Max. Speed	[m/s]	3.0	5.0	
Linear motion per revolution of drive shaft	[mm/U]	108	160	
Max. rpm. drive shaft	[min ⁻¹]	1700	1875	
Max. effective action force F_A at speed	1 m/s	[N]	650	1430
	1 - 2 m/s	[N]	450	1200
	> 3 - 5 m/s	[N]	–	1050
No-load torque ²⁾	[Nm]	0.6	1.2	
Max. acceleration/deceleration	[m/s ²]	20	20	
Repeatability	+/- [mm/m]	0.05	0.05	
Max. standard stroke length ¹⁾	[mm]	1000	1500	
Max. recommended permissible mass ³⁾	[kg]	10	20	

¹⁾ Longer strokes on request

²⁾ As a result of static friction force

³⁾ vertical

Maximum Permissible Torque on Drive Shaft Speed / Stroke

OSP-E-20BV				OSP-E-25BV			
Speed [m/s]	Torque [Nm]	Stroke [m]	Torque [Nm]	Speed [m/s]	Torque [Nm]	Stroke [m]	Torque [Nm]
1	19	1	17	1	36	1	36
2	17	2	11	2	30	2	36
3	16			3	30		
				4	28		
				5	27		

Important:

The maximum permissible torque on the drive shaft is the lowest value of the speed or stroke-dependent torque value.

Example above:

OSP-E25BV required speed $v = 3$ m/s and stroke = 1 m.

Accordingly Table T2 shows permissible moments of 30 Nm for the speed and 36 Nm for the stroke. Therefore the maximum moment at the drive shaft is determined by the speed and must not exceed 30 Nm.

Loads, Forces and Moments

Combined loads

If the actuator is subjected to several forces, loads and moments at the same time, the maximum load is calculated with the equation shown here.

The maximum permissible loads must not be exceeded.

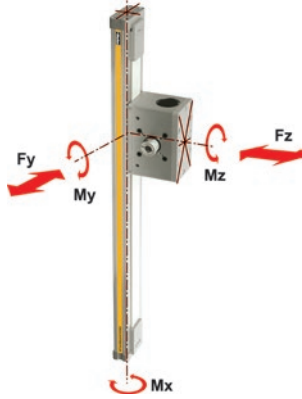

$$M = F \cdot l \text{ [Nm]}$$

$$M_x = M_{x \text{ static}} + M_{x \text{ dynamic}}$$

$$M_y = M_{y \text{ static}} + M_{y \text{ dynamic}}$$

$$M_z = M_{z \text{ static}} + M_{z \text{ dynamic}}$$

The distance l (l_x , l_y , l_z) for calculation of the bending moments relates to the centre axis of the actuator.

Maximum Permissible Loads

Size	Max. applied load [N]		Max. moments [Nm]		
	Fy [N]	Fz [N]	Mx	My	Mz
OSP-E20BV	1600	1600	20	100	100
OSP-E25BV	2000	3000	50	200	200

Equation of Combined Loads

$$\frac{F_z}{F_z \text{ (max)}} + \frac{M_x}{M_x \text{ (max)}} + \frac{M_y}{M_y \text{ (max)}} + \frac{M_z}{M_z \text{ (max)}} \leq 1$$

The total of the loads must not exceed >1 under any circumstances.

Distance of Centre of Gravity of External Mass from Mid-Point of Actuator

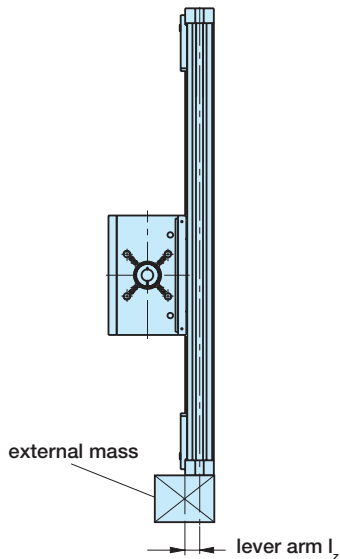

Mass [kg]	OSP-E20BV		OSP-E25BV	
	Lever arm l_z [mm]	Max. permissible acceleration/ deceleration [m/s ²]	Lever arm l_z [mm]	Max. permissible acceleration/ deceleration [m/s ²]
> 3 to 5	0	20	50	20
> 5 to 10	0	20	40	20
> 10 to 15	-	-	35	20
> 15 to 20	-	-	30	15

Options and Accessories

OSP-E..BV, Vertical belt actuator with integrated ball bearing guide

STANDARD VERSION OSP-E..BV

Standard actuator head with clamp shaft or plain shaft and integrated ball bearing guide with two carriers.
 Choice of side on which gearbox or motor is to be mounted.

DRIVE SHAFT
 "CLAMP SHAFT AND PLAIN SHAFT" OR "DOUBLE PLAIN SHAFT"
 e.g. for parallel operation of two Z-axes with an intermediate drive shaft.

ACCESSORIES

MOTOR MOUNTINGS
 For connection of gearbox or motor direct to drive shaft with clamp shaft, or with a motor coupling to drive shaft with plain shaft.

Drive Shaft with Clamp Shaft



Drive Shaft with Plain Shaft



Drive Shaft with Clamp Shaft and Plain Shaft



Drive Shaft with Double Plain Shaft



MAGNETIC SWITCHES SET
 Magnetic switches with connector, mounting rail and magnets for contactless sensing of the end positions. Cable (suitable for cable chain) can be ordered separately in 5 m, 10 m or 15 m length.

OPTIONS

TANDEM
 Additional actuator head and two additional carriers for higher bending moments.



HOLLOW SHAFT WITH KEYWAY
 For direct connection of gearbox or motor with keyway.

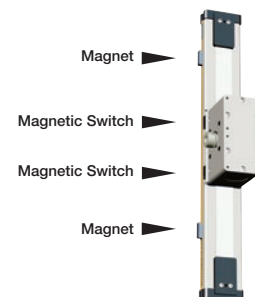

MULTI-AXIS SYSTEMS
 For modular assembly of actuators up to multi-axis systems.

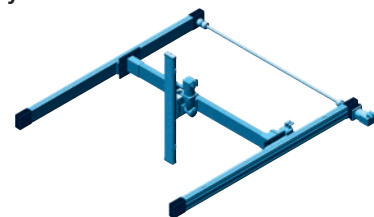

HMR - Electromechanical Linear Actuator



Profile designs

- Basic profile for assembling directly to the machine base
- Reinforced profile for self-supporting assembly



Mounting systems

- Integrated T-slots for attaching from below and from the side

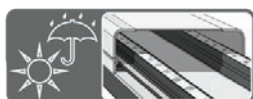

Protection classes

- Without cover: Standard
- With cover: IP54



Guide system

- Recirculating ball bearing guide



Lubrication

- Central lubrication via externally accessible lubricating nipples

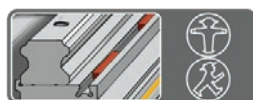

Position sensing

- Integrated, adjustable position switch for end positions and homing



Impact protection

- Integrated shock absorbers for both end positions

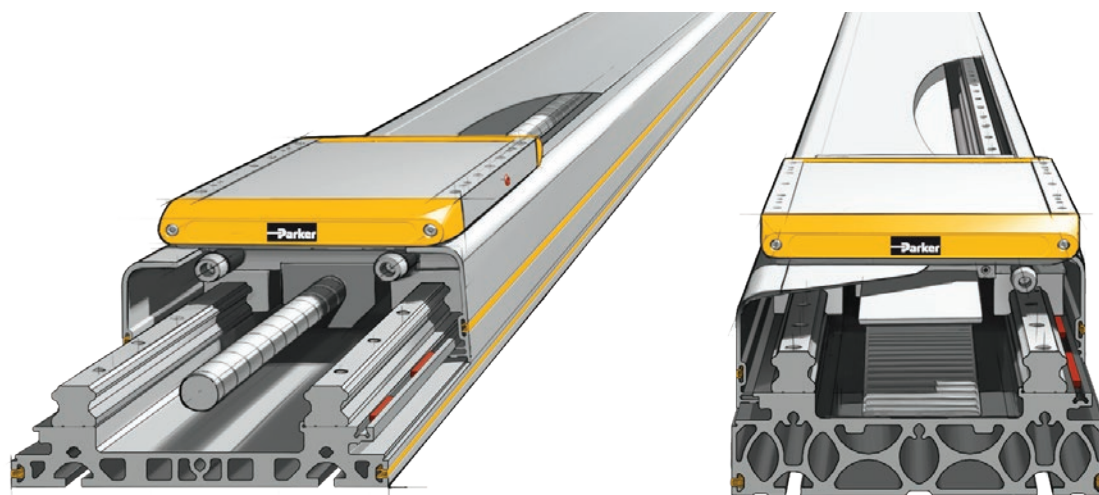

Screw drive

The solution for precise path and position control for heavy loads



Toothed belt drive

The solution for fast path and position control for medium loads

Sizes 85, 110, 150, 180, 240 mm

Load requirements for guides and installation size.

The occurring loads, forces and bending moments depend on the application. The mass of the construction attached to the carriage has a center of gravity. This mass creates static forces ($F = m \cdot g$) and bending moments ($M = m \cdot g \cdot l$). Additional dynamic moments ($M = m \cdot a \cdot l$) arise in dependence of the acceleration during travel. Care should be taken when selecting suitable guides that the permissible sum of loads does not exceed 1.

Loads, forces and bending moments

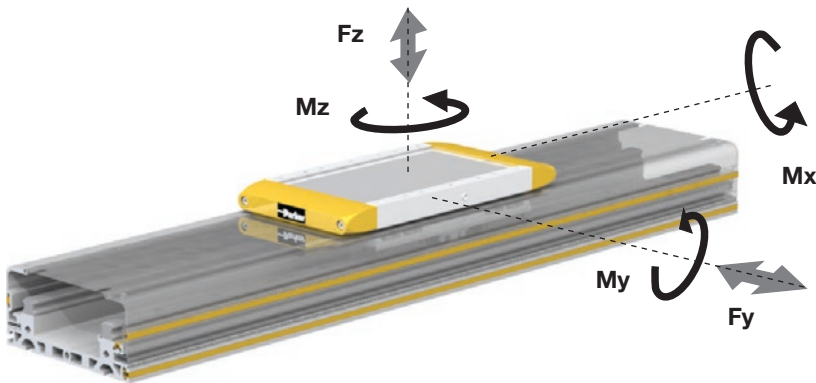

Internal lever arm l_{zi}

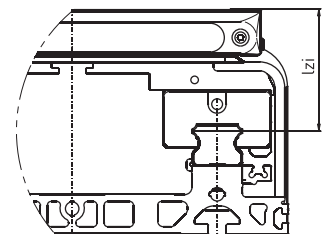

Dimensions - Internal lever arm l_{zi}

Product size	[mm]	l_{zi}
HMRx085	[mm]	33.0
HMRx110	[mm]	39.5
HMRx150	[mm]	50.0
HMRx180	[mm]	57.5
HMRx240	[mm]	68.0

Combined loads

The maximum permissible load for linear drives subject to simultaneous multiple loads, forces and bending moments are calculated using the formula below.

$$L = \frac{F_y}{F_{y(max)}} + \frac{F_z}{F_{z(max)}} + \frac{M_x}{M_{x(max)}} + \frac{M_y}{M_{y(max)}} + \frac{M_z}{M_{z(max)}} \leq 1$$

Maximum permissible loads must not be exceeded.

The sum of all loads must under no circumstance be > 1 .

Parker Electromechanical Actuators
HMR - Electromechanical Linear Actuator

Maximum permissible loads based on a performance of 2,540 km

Product Size	HMRx08	HMRx11	HMRx15	HMRx18	HMRx24	HMRx08	HMRx11	HMRx15	HMRx18	HMRx24	
Carriage	Standard					Tandem					
Max. permissible load											
F_{z2540} F_{y2540}	[N]	1,800	4,450	8,800	16,200	26,600	2,700	6,700	13,200	24,300	39,900
Max. permissible bending moment											
M_{x2540}	[Nm]	45	155	430	940	2,150	68	235	645	1,410	3,225
M_{y2540} M_{z2540}	[Nm]	80	200	560	1,230	2,430	120	300	840	1,845	3,645

Maximum permissible loads based on a performance of 8,000 km

Product Size	HMRx08	HMRx11	HMRx15	HMRx18	HMRx24	HMRx08	HMRx11	HMRx15	HMRx18	HMRx24	
Carriage	Standard					Tandem					
Max. permissible load											
F_{z8000} F_{y8000}	[N]	1,250	3,000	6,000	11,000	18,200	1,875	4,500	9,000	16,500	27,300
Max. permissible bending moment											
M_{x8000}	[Nm]	30	105	290	640	1,460	45	160	435	960	2,190
M_{y8000} M_{z8000}	[Nm]	55	135	380	840	1,660	80	205	570	1,260	2,490

Series HMRS / Ball Screw / Drive Data



Series HMRS / Ball Screw / Drive Data / Sizes 85, 110, 150, 180, 240 mm

Technical Data HMRS

Product Size			HMRS08		HMRS11		HMRS15		HMRS18		HMRS24	
Type of Screw			12 x 5	12 x 12	16 x 5	16 x 16	20 x 5	20 x 20	25 x 10	25 x 25	32 x 10	32 x 32
Pitch	p	[mm]	5	12	5	16	5	20	10	25	10	32
Max. speed	v_{max}	[m/s]	0.25	0.60	0.25	0.80	0.25	1.00	0.50	1.25	0.50	1.60
Max. acceleration	a_{max}	[m/s ²]	10		10		10		10		10	
Repeatability		[µm]	± 20		± 20		± 20		± 20		± 20	
Max. stroke		[mm]	1,200		1,500		2,500		3,400		4,000	

Thrust force and torque

Max. thrust force	F_{Amax}	[N]	820	820	2,200	2,200	2,600	2,600	4,800	4,800	5,500	5,500
	F_{A2540}	[N]	820	650	1,550	1,150	1,800	2,160	3,300	3,960	3,500	4,880
Max. torque at drive shaft	M_{Amax}	[Nm]	0.7	1.7	1.9	6.1	2.2	9.0	8.3	20.8	9.5	30.4
	M_{A2540}	[Nm]	0.7	1.3	1.3	3.1	1.6	7.5	5.7	17.1	6.1	27.0
No load torque	M_0	[Nm]	0.2	0.2	0.3	0.4	0.7	0.9	0.9	1.0	1.0	1.1

Stroke dependent speed

Max. permissible speed at order stroke	200	[mm]	250	600	250	800	250	1,000	500	1,250	500	1,600
	400	[mm]	250	600	250	800	250	1,000	500	1,250	500	1,600
	600	[mm]	152	366	197	631	250	1,000	500	1,250	500	1,600
	800	[mm]	102	245	132	424	169	678	382	956	423	1,354
	1000	[mm]	73	176	95	304	122	486	277	694	312	997
	1200	[mm]	55	132	71	228	91	366	211	526	239	765
	1400	[mm]	-	-	56	178	71	285	165	413	189	605
	1600	[mm]	-	-	45	143	57	228	133	333	153	491
	1800	[mm]	-	-	-	-	47	187	109	274	127	406
	2000	[mm]	-	-	-	-	39	156	92	229	107	342
	2200	[mm]	-	-	-	-	33	132	78	195	91	291
	2400	[mm]	-	-	-	-	28	113	67	167	79	251
	2600	[mm]	-	-	-	-	-	-	58	145	68	219
	2800	[mm]	-	-	-	-	-	-	51	128	60	193
	3000	[mm]	-	-	-	-	-	-	45	113	53	171
	3200	[mm]	-	-	-	-	-	-	40	100	48	152
	3400	[mm]	-	-	-	-	-	-	-	-	43	137
3600	[mm]	-	-	-	-	-	-	-	-	39	123	
3800	[mm]	-	-	-	-	-	-	-	-	35	112	
4000	[mm]	-	-	-	-	-	-	-	-	32	102	

Series HMRB / Belt / Drive Data

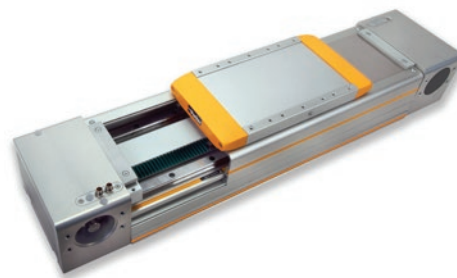

Description Motor mounting position

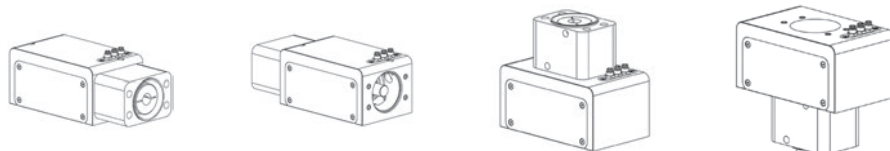

horizontal		upright	
090° / 270°		000° / 180°	
BD, DD		AP, CP, AD, CD	

Type and orientation of the belt is given by the motor mounting position.

Technical data HMRB

Production size			HMRB08		HMRB11		HMRB15	
Motor mounting position			090° / 270°	000° / 180°	090° / 270°	000° / 180°	090° / 270°	000° / 180°
Lead constant	$s_{lin.}$	[mm]	66	66	90	90	100	125
Max. speed	$v_{max.}$	[m/s]	2		2		5	
Max. acceleration	$a_{max.}$	[m/s ²]	30		30		50	
Repeatability		[μm]			± 50			
Max. order stroke		[mm]	3,000		4,000		6,000	
Thrust force and torque								
Max. thrust force	$F_{A.max.}$	[N]	295	295	630	630	1,050	630
Max. torque on drive shaft	$M_{A.max.}$	[Nm]	3.1	3.1	9.0	9.0	17.0	13.0
No load torque	M_0	[Nm]	1.0	1.0	1.2	1.2	1.2	1.2

Technical data HMRB

Production size			HMRB18		HMRB24	
Motor mounting position			090° / 270°	000° / 180°	090° / 270°	000° / 180°
Lead constant	$s_{lin.}$	[mm]	130	150	160	224
Max. speed	$v_{max.}$	[m/s]	5		5	
Max. acceleration	$a_{max.}$	[m/s ²]	50		50	
Repeatability		[μm]	± 50		± 50	
Max. order stroke		[mm]	6,000		6,000	
Thrust force and torque						
Max. thrust force	$F_{A.max.}$	N	1,300	1,000	4,000	3,750
Max. torque on drive shaft	$M_{A.max.}$	Nm	27	24	101	134
No load torque	M_0	Nm	2.0	2.0	4.0	4.0

Series HMRB / Belt / Thrust Force

The permissible thrust force from the table is depending on speed level and order stroke length. The minimum thrust force value must not be exceeded in the application.

Information: Limiting the torque from the motor may avoid exceeding permitted thrust force.

HMRB thrust force

Product size			HMRB08		HMRB11		HMRB15		HMRB18		HMRB24	
Motor mounting position			090° / 270°	000° / 180°	090° / 270°	000° / 180°	090° / 270°	000° / 180°	090° / 270°	000° / 180°	090° / 270°	000° / 180°
Thrust force F_A corresponding to speed v	$F_{A(v<1 \text{ m/s})}$	[N]	295	295	630	630	1,050	630	1,300	1,000	4,000	3,750
	$F_{A(v<2 \text{ m/s})}$	[N]	295	295	550	550	990	630	1,300	1,000	4,000	3,380
	$F_{A(v<3 \text{ m/s})}$	[N]	-	-	-	-	930	630	1,300	1,000	3,650	3,140
	$F_{A(v<4 \text{ m/s})}$	[N]	-	-	-	-	890	630	1,300	1,000	3,370	2,950
	$F_{A(v<5 \text{ m/s})}$	[N]	-	-	-	-	840	630	1,300	1,000	3,200	2,800
Thrust force F_A corresponding to order stroke length OS	$F_{A(OS<1000 \text{ mm})}$	[N]	250	250	630	630	1,050	630	1,300	1,000	4,000	3,750
	$F_{A(OS<2000 \text{ mm})}$	[N]	140	140	550	550	820	490	1,000	775	4,000	3,360
	$F_{A(OS<3000 \text{ mm})}$	[N]	100	100	385	385	570	340	710	550	3,370	2,440
	$F_{A(OS<4000 \text{ mm})}$	[N]	-	-	295	295	445	265	550	430	2,860	1,880
	$F_{A(OS<5000 \text{ mm})}$	[N]	-	-	-	-	365	215	450	350	2,350	1,540
	$F_{A(OS<6000 \text{ mm})}$	[N]	-	-	-	-	305	185	380	295	2,000	1,300

Example:

HMRB18 with motor mounting position 1 (090° front), speed $v = 2 \text{ m/s}$ ($F_A = 1,300 \text{ N}$) and order stroke length $OS = 2,500 \text{ mm}$ ($F_A = 710 \text{ N}$).
The maximum permissible thrust force $F_A = 710 \text{ N}$ must not be exceeded.

HMR Series
Profile Versions
Sizes 85, 110, 150, 180, 240 mm

Designs

- **Basic**
- **Reinforced**

The HMR linear drive system can be equipped with a “basic” or “reinforced” profile as standard. The “basic” profile is suitable for fitting directly to a machine base that has a corresponding support surface. The “reinforced” profile, on the other hand, is the preferred choice for self-supporting systems or for use in conjunction with a base surface offering limited support. The permissible temperature range for both profile versions is -20°C ... +80°C.

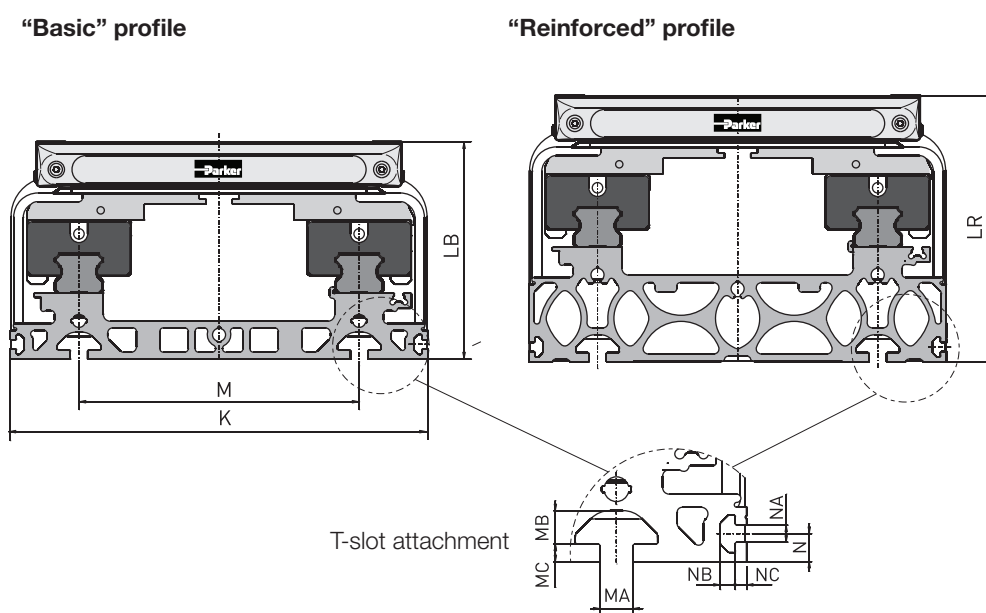

Dimensions - Profil design HMR

Product Size	K	LB	LR	M	MA	MB	MC	N	NA	NB	NC
HMRx085 [mm]	85.0	60.0	71.0	50.0	5.2	4.5	1.5	4.5	3.4	3.0	2.5
HMRx110 [mm]	110.0	69.5	89.5	70.0	5.2	4.5	1.8	4.5	3.4	3.0	2.5
HMRx150 [mm]	150.0	90.0	114.0	96.0	6.2	6.8	3.0	6.5	5.2	4.6	3.5
HMRx180 [mm]	180.0	111.5	134.5	116.0	8.0	7.8	4.5	8.5	5.2	4.5	3.5
HMRx240 [mm]	240.0	125.0	153.0	161.0	10.0	10.2	5.3	8.5	5.2	4.5	3.5

HMR Series
Profile version „reinforced“
Sizes 85, 110, 150, 180, 240 mm

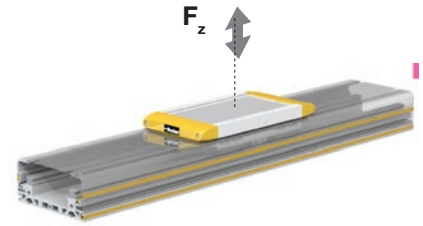

Max. admissible loads [N] and supporting distances [mm] (self-supporting)

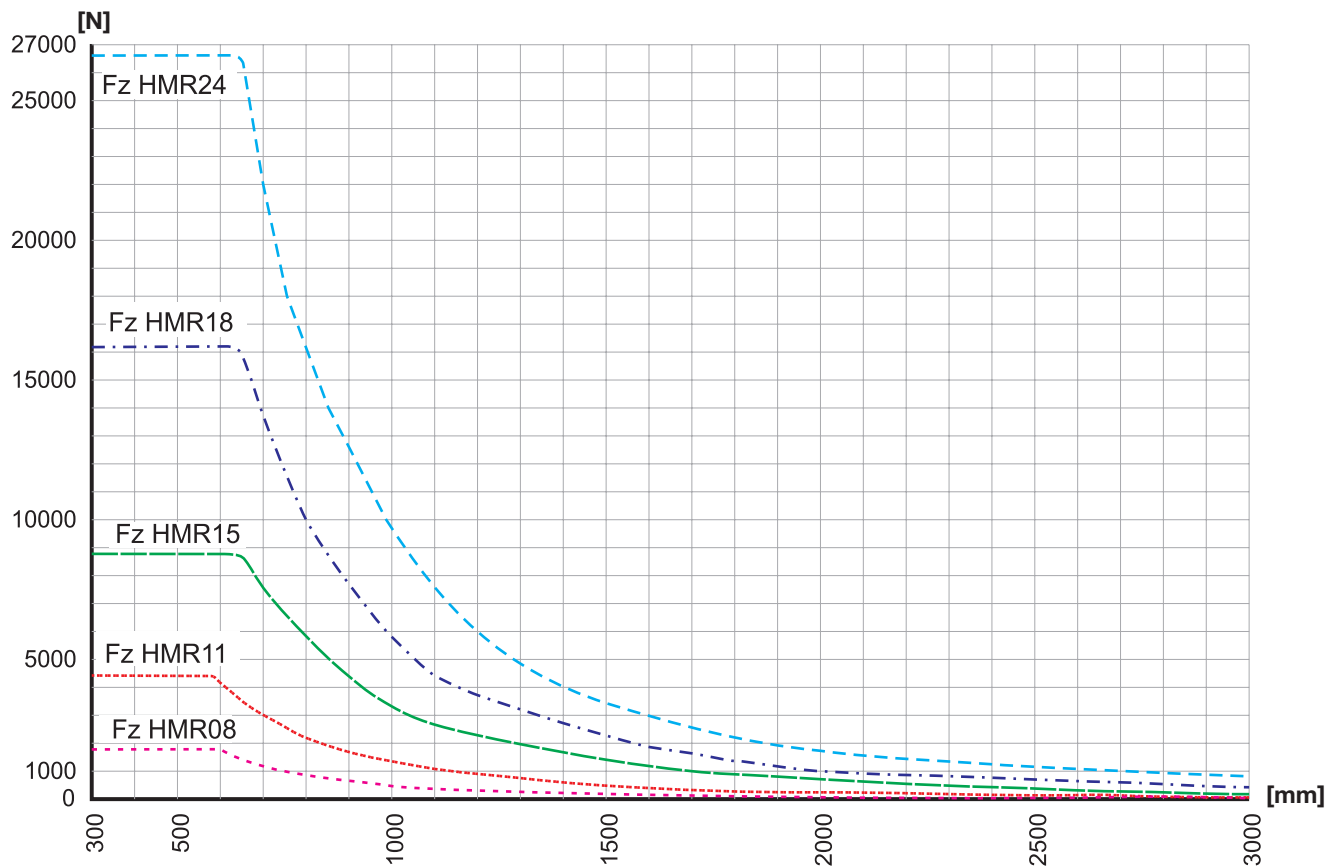

Example F_z HMR 11:

For a 2.800 N load the distance „D“ between supporting elements is 720 mm.
Mounting accessories see „Accessories / T-Slot Mounting“

HMR series
Profile version „reinforced“
Sizes 85, 110, 150, 180, 240 mm

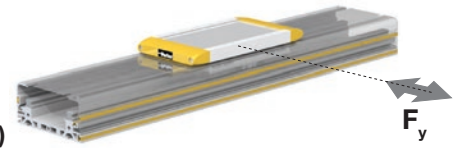

Max. admissible loads [N] and supporting distances [mm] (self-supporting)

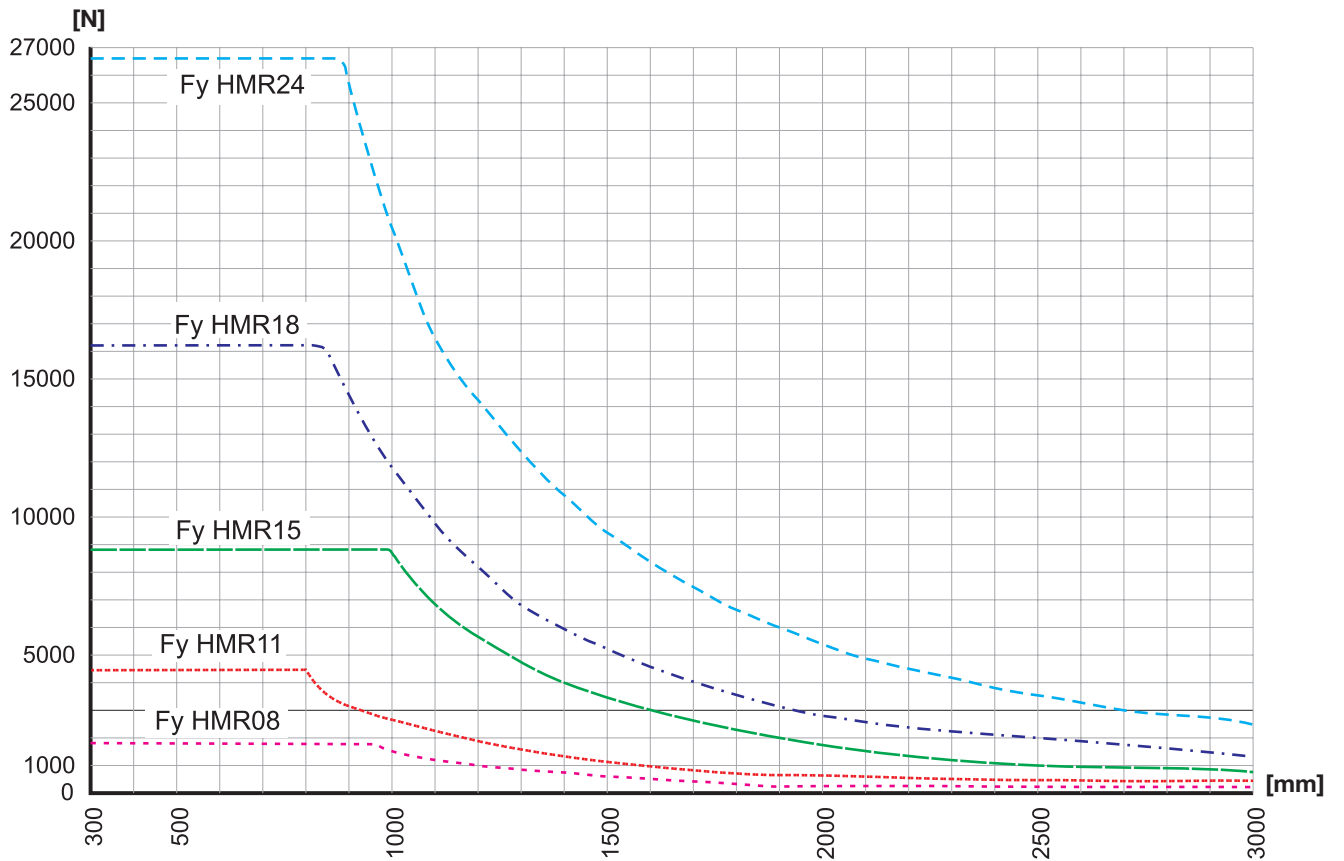

Example F_y HMR 11:

For a 3.160 N load the distance „D“ between supporting elements is 900 mm.
Mounting accessories see „Accessories / T-Slot Mounting“



Parker's Motion & Control Technologies

At Parker, we're guided by a relentless drive to help our customers become more productive and achieve higher levels of profitability by engineering the best systems for their requirements. It means looking at customer applications from many angles to find new ways to create value. Whatever the motion and control technology need, Parker has the experience, breadth of product and global reach to consistently deliver. No company knows more about motion and control technology than Parker. For further info call 00800 27 27 5374



Aerospace

Key Markets

Aftermarket services
Commercial transports
Engines
General & business aviation
Helicopters
Launch vehicles
Military aircraft
Missiles
Power generation
Regional transports
Unmanned aerial vehicles

Key Products

Control systems & actuation products
Engine systems & components
Fluid conveyance systems & components
Fluid metering, delivery & atomization devices
Fuel systems & components
Fuel tank inerting systems
Hydraulic systems & components
Thermal management
Wheels & brakes



Climate Control

Key Markets

Agriculture
Air conditioning
Construction Machinery
Food & beverage
Industrial machinery
Life sciences
Oil & gas
Precision cooling
Process
Refrigeration
Transportation

Key Products

Accumulators
Advanced actuators
CO₂ controls
Electronic controllers
Filter driers
Hand shut-off valves
Heat exchangers
Hose & fittings
Pressure regulating valves
Refrigerant distributors
Safety relief valves
Smart pumps
Solenoid valves
Thermostatic expansion valves



Electromechanical

Key Markets

Aerospace
Factory automation
Life science & medical
Machine tools
Packaging machinery
Paper machinery
Plastics machinery & converting
Primary metals
Semiconductor & electronics
Textile
Wire & cable

Key Products

AC/DC drives & systems
Electric actuators, gantry robots & slides
Electrohydraulic actuation systems
Electromechanical actuation systems
Human machine interface
Linear motors
Stepper motors, servo motors, drives & controls
Structural extrusions



Filtration

Key Markets

Aerospace
Food & beverage
Industrial plant & equipment
Life sciences
Marine
Mobile equipment
Oil & gas
Power generation & renewable energy
Process
Transportation
Water Purification

Key Products

Analytical gas generators
Compressed air filters & dryers
Engine air, coolant, fuel & oil filtration systems
Fluid condition monitoring systems
Hydraulic & lubrication filters
Hydrogen, nitrogen & zero air generators
Instrumentation filters
Membrane & fiber filters
Microfiltration
Sterile air filtration
Water desalination & purification filters & systems



Fluid & Gas Handling

Key Markets

Aerial lift
Agriculture
Bulk chemical handling
Construction machinery
Food & beverage
Fuel & gas delivery
Industrial machinery
Life sciences
Marine
Mining
Mobile
Oil & gas
Renewable energy
Transportation

Key Products

Check valves
Connectors for low pressure fluid conveyance
Deep sea umbilicals
Diagnostic equipment
Hose couplings
Industrial hose
Mooring systems & power cables
PTFE hose & tubing
Quick couplings
Rubber & thermoplastic hose
Tube fittings & adapters
Tubing & plastic fittings



Hydraulics

Key Markets

Aerial lift
Agriculture
Alternative energy
Construction machinery
Forestry
Industrial machinery
Machine tools
Marine
Material handling
Mining
Oil & gas
Power generation
Refuse vehicles
Renewable energy
Truck hydraulics
Turf equipment

Key Products

Accumulators
Cartridge valves
Electrohydraulic actuators
Human machine interfaces
Hybrid drives
Hydraulic cylinders
Hydraulic motors & pumps
Hydraulic systems
Hydraulic valves & controls
Hydrostatic steering
Integrated hydraulic circuits
Power take-offs
Power units
Rotary actuators
Sensors



Pneumatics

Key Markets

Aerospace
Conveyor & material handling
Factory automation
Life science & medical
Machine tools
Packaging machinery
Transportation & automotive

Key Products

Air preparation
Brass fittings & valves
Manifolds
Pneumatic accessories
Pneumatic actuators & grippers
Pneumatic valves & controls
Quick disconnects
Rotary actuators
Rubber & thermoplastic hose & couplings
Structural extrusions
Thermoplastic tubing & fittings
Vacuum generators, cups & sensors



Process Control

Key Markets

Alternative fuels
Biopharmaceuticals
Chemical & refining
Food & beverage
Marine & shipbuilding
Medical & dental
Microelectronics
Nuclear Power
Offshore oil exploration
Oil & gas
Pharmaceuticals
Power generation
Pulp & paper
Steel
Water/wastewater

Key Products

Analytical Instruments
Analytical sample conditioning products & systems
Chemical injection fittings & valves
Fluoropolymer chemical delivery fittings, valves & pumps
High purity gas delivery fittings, valves, regulators & digital flow controllers
Industrial mass flow meters/ controllers
Permanent no-weld tube fittings
Precision industrial regulators & flow controllers
Process control double block & bleeds
Process control fittings, valves, regulators & manifold valves



Sealing & Shielding

Key Markets

Aerospace
Chemical processing
Consumer
Fluid power
General industrial
Information technology
Life sciences
Microelectronics
Military
Oil & gas
Power generation
Renewable energy
Telecommunications
Transportation

Key Products

Dynamic seals
Elastomeric o-rings
Electro-medical instrument design & assembly
EMI shielding
Extruded & precision-cut, fabricated elastomeric seals
High temperature metal seals
Homogeneous & inserted elastomeric shapes
Medical device fabrication & assembly
Metal & plastic retained composite seals
Shielded optical windows
Silicone tubing & extrusions
Thermal management
Vibration dampening

Parker Worldwide

Europe, Middle East, Africa

AE – United Arab Emirates, Dubai
Tel: +971 4 8127100
parker.me@parker.com

AT – Austria, St. Florian
Tel: +43 (0)7224 66201
parker.austria@parker.com

AZ – Azerbaijan, Baku
Tel: +994 50 2233 458
parker.azerbaijan@parker.com

BE/NL/LU – Benelux, Hendrik Ido Ambacht
Tel: +31 (0)541 585 000
parker.nl@parker.com

BG – Bulgaria, Sofia
Tel: +359 2 980 1344
parker.bulgaria@parker.com

BY – Belarus, Minsk
Tel: +48 (0)22 573 24 00
parker.poland@parker.com

CH – Switzerland, Etoy
Tel: +41 (0)21 821 87 00
parker.switzerland@parker.com

CZ – Czech Republic, Klecany
Tel: +420 284 083 111
parker.czechrepublic@parker.com

DE – Germany, Kaarst
Tel: +49 (0)2131 4016 0
parker.germany@parker.com

DK – Denmark, Ballerup
Tel: +45 43 56 04 00
parker.denmark@parker.com

ES – Spain, Madrid
Tel: +34 902 330 001
parker.spain@parker.com

FI – Finland, Vantaa
Tel: +358 (0)20 753 2500
parker.finland@parker.com

FR – France, Contamine s/Arve
Tel: +33 (0)4 50 25 80 25
parker.france@parker.com

GR – Greece, Piraeus
Tel: +30 210 933 6450
parker.greece@parker.com

HU – Hungary, Budaörs
Tel: +36 23 885 470
parker.hungary@parker.com

IE – Ireland, Dublin
Tel: +353 (0)1 466 6370
parker.ireland@parker.com

IL – Israel
Tel: +39 02 45 19 21
parker.israel@parker.com

IT – Italy, Corsico (MI)
Tel: +39 02 45 19 21
parker.italy@parker.com

KZ – Kazakhstan, Almaty
Tel: +7 7273 561 000
parker.easteurope@parker.com

NO – Norway, Asker
Tel: +47 66 75 34 00
parker.norway@parker.com

PL – Poland, Warsaw
Tel: +48 (0)22 573 24 00
parker.poland@parker.com

PT – Portugal
Tel: +351 22 999 7360
parker.portugal@parker.com

RO – Romania, Bucharest
Tel: +40 21 252 1382
parker.romania@parker.com

RU – Russia, Moscow
Tel: +7 495 645-2156
parker.russia@parker.com

SE – Sweden, Borås
Tel: +46 (0)8 59 79 50 00
parker.sweden@parker.com

SK – Slovakia, Banská Bystrica
Tel: +421 484 162 252
parker.slovakia@parker.com

SL – Slovenia, Novo Mesto
Tel: +386 7 337 6650
parker.slovenia@parker.com

TR – Turkey, Istanbul
Tel: +90 216 4997081
parker.turkey@parker.com

UA – Ukraine, Kiev
Tel: +48 (0)22 573 24 00
parker.poland@parker.com

UK – United Kingdom, Warwick
Tel: +44 (0)1926 317 878
parker.uk@parker.com

ZA – South Africa, Kempton Park
Tel: +27 (0)11 961 0700
parker.southafrica@parker.com

North America

CA – Canada, Milton, Ontario
Tel: +1 905 693 3000

US – USA, Cleveland
Tel: +1 216 896 3000

Asia Pacific

AU – Australia, Castle Hill
Tel: +61 (0)2-9634 7777

CN – China, Shanghai
Tel: +86 21 2899 5000

HK – Hong Kong
Tel: +852 2428 8008

IN – India, Mumbai
Tel: +91 22 6513 7081-85

JP – Japan, Tokyo
Tel: +81 (0)3 6408 3901

KR – South Korea, Seoul
Tel: +82 2 559 0400

MY – Malaysia, Shah Alam
Tel: +60 3 7849 0800

NZ – New Zealand, Mt Wellington
Tel: +64 9 574 1744

SG – Singapore
Tel: +65 6887 6300

TH – Thailand, Bangkok
Tel: +662 186 7000

TW – Taiwan, Taipei
Tel: +886 2 2298 8987

South America

AR – Argentina, Buenos Aires
Tel: +54 3327 44 4129

BR – Brazil, Sao Jose dos Campos
Tel: +55 800 727 5374

CL – Chile, Santiago
Tel: +56 2 623 1216

MX – Mexico, Toluca
Tel: +52 72 2275 4200

EMEA Product Information Centre

Free phone: 00 800 27 27 5374

(from AT, BE, CH, CZ, DE, DK, EE, ES, FI, FR, IE, IL, IS, IT, LU, MT, NL, NO, PL, PT, RU, SE, SK, UK, ZA)

US Product Information Centre

Toll-free number: 1-800-27 27 537

www.parker.com

Your local authorized Parker distributor

