

# 635



**EUROTHERM  
DRIVES**

## ***DIGITAL SERVO DRIVE***



B-07-01-05-06-001.jpg

**PRODUCT  
MANUAL**



## Further descriptions, that relate to this document.

UL: 07-01-01-01



Product - manual Rack 3U

---

UL: 07-01-01-02



Product - manual EMC-Rack 3 U

---

UL: 07-01-02-02



Product - manual Power supply plug – in module / 3U

---

UL: 07-05-02-03



Product - manual SUCOnet K

---

UL: 07-05-03-02



Product - manual Businterface CAN for 635 637 637+

---

UL: 07-05-04-02



Product - manual Businterface DP for 635 637 637+

---

UL: 07-05-05-02



Product - manual Businterface Interbus S for 635 637 637+

---

## Further descriptions, that relate to this document.

UL: 07-05-07-02



Product - manual IO Interface for 635 637 637+

---

UL: 07-09-04-02



Product - manual Supression aids EH

---

UL: 10-06-03



Product - manual Serial transfer protocol  
635 637 637+ EASY-seriell

---

UL: 10-06-05



Product - manual BIAS Command Description

---

UL: 12



Product - manuals Accessories

---

© **EUROTHERM** Drives Limited.

All rights reserved. No portion of this description may be produced or processed in any form without the consent of the company.

Changes are subject to change without notice.

**EUROTHERM** has registered in part trademark protection and legal protection of designs.  
The handing over of the descriptions may not be construed as the transfer of any rights.

Made in Germany, 2002



# CONTENTS

	Page
<b>The most important thing first.....</b>	<b>6</b>
<b>Saferecaytuptions .....</b>	<b>7</b>
<b>1 General .....</b>	<b>9</b>
1.1 System description.....	9
1.1.1 Digital communication .....	11
1.1.2 Operation configurations .....	11
1.1.3 Compatibility to Eurotherm- 3 U analog regulator ESR AC S .....	12
1.1.4 Compatibility to series APOLLO 2G .....	12
1.2 Key to the models .....	13
1.3 Range data .....	14
1.3.1 Insulation concept.....	14
1.3.2 Generally data.....	14
1.3.3 Compact units 635/K DER.....	15
1.3.4 Plug-in modules 635/DER.....	16
1.3.5 Single- and three-phase supply.....	17
1.3.6 Output power .....	18
1.4 Dimensions and layout .....	19
1.4.1 Dimensions for compact device and plug-in module .....	19
1.4.2 EMC bow (optional).....	20
1.4.3 Layout.....	21
<b>2 General view of connections .....</b>	<b>22</b>
2.1 of the <u>compact device</u> 635/K DER 01...10 .....	22
2.2 Connector pin assignments and contact functions.....	23
2.2.1 Power connections for <u>plug-in module</u> 635/DER standard .....	23
2.2.2 for plug-in module 635/DER ...-N (with integrated power supply) special .....	24
2.2.3 Signal connections .....	25
2.2.3 Resolver.....	28
2.2.4 Multifunktion X40.....	29
2.2.5 Digital interfaces.....	33
<b>3 Operating modes.....</b>	<b>39</b>
3.1 Operating modes and pin functions .....	40
3.2 Configurable pin-functions (depending on the operating mode).....	41
3.3 Function diagrams from inputs and outputs .....	42
<b>4 Mechanical installation .....</b>	<b>43</b>
4.1 Mounting .....	43
4.2 Control cabinet - mounting.....	43
4.3 Cooling .....	43
<b>5 Electrical installation.....</b>	<b>44</b>
5.1 Safety .....	44
5.2 The danger of electric shocks .....	44
5.3 Danger areas .....	44
5.4 Grounding, safety grounding .....	44
5.4.1 Ground connections.....	44
5.5 Short-circuit capability and discharge currents .....	44
5.6 Fuses, contactors, filters .....	45
5.7 Brake resistor .....	46
5.7.1 Selection of the brake resistor .....	46
5.7.2 Configuration of the brake resistor .....	47
5.7.3 Additional informations.....	48

# CONTENTS

	Page
<b>6</b>	<b>Wiring instructions ..... 49</b>
6.1	General Information..... 49
6.2	Control cabling ..... 49
6.3	Power cabling ..... 49
6.4	Installation of the rack ..... 49
6.5	Analog setpoint..... 49
6.6	Safety rules ..... 49
6.7	Electromagnetic compatibility (EMC) ..... 49
6.7.1	Hints for mounting ..... 50
6.7.2	Example for mounting..... 51
6.7.3	Achievable specifications and conditions..... 52
<b>7</b>	<b>Setting and programming..... 53</b>
7.1	Jumper ..... 53
7.2	Digital communication ..... 53
7.3	PROG-key functions..... 53
7.3.1	Description for PROG-key ..... 53
7.3.2	Bedienung des PROG-Tasters ..... 54
<b>8</b>	<b>Commissioning..... 55</b>
8.1	Preparation..... 55
8.2	Commissioning in steps..... 56
<b>9</b>	<b>Diagnosis and trouble shooting ..... 59</b>
9.1	7-Segment-display ..... 59
9.2	Reset of a regulator trouble ..... 61
9.3	Trouble shooting..... 62
<b>10</b>	<b>Block circuit diagram..... 63</b>
<b>11</b>	<b>General technical data..... 64</b>
11.1	Power circuit..... 64
11.2	Control circuit..... 64
11.3	Signal inputs and outputs, connection X10 ..... 64
11.4	Digital control..... 65
11.5	Digital communication ..... 65
11.6	Resolverauswertung/ Transmitterprinzip ..... 65
11.7	Controllersystem..... 66
11.8	Measuring sockets MP1 and MP2..... 66
11.9	Thermal data..... 66
11.10	Mechanical data..... 66
<b>12</b>	<b>Disposal..... 67</b>
<b>13</b>	<b>Software..... 68</b>
13.1	EASYRIDER  ..... 68
13.2	BIAS- commands ..... 69
13.3	BIAS- extended command overview..... 71
<b>14</b>	<b>Certificates ..... 72</b>
<b>15</b>	<b>Index ..... 76</b>
<b>16</b>	<b>Notes..... 77</b>
<b>17</b>	<b>Modification Record..... 78</b>



## The most important thing first

We thank you for the trust that you have shown in our product.

The operating instructions presented hereserves as an overview of the technical data and features.

Please read the operating instructions before putting the product to use.

If you have any questions, please contact your nearest Eurotherm representative.

Improper application of the product in connection with dangerous voltage, can lead to injuries.

In addition, damage can also occur to motors or other products.

Therefore please observe strictly our safety precautions.

Topic: Safety precautions

We assume that as an expert, you are familiar with the relevant safety regulations, especially in accordance with VDE 0100, VDE 0113, VDE 0160, EN 50178, the accident prevention regulations of the employers liability insurance company and the DIN regulations and that you can use and apply them. Also the CE - regulations are to be observed and guaranteed.

Depending on the kind of application, additional norms e.g. UL, DIN are to be observed.

If our products are employed in connection with components from other manufacturers, their operating instructions are also to be strictly observed.

## Safety precautions



### **Attention !**

The digital servo drives are in the sense of EN 50178/VDE 0160 power electronic equipments for regulating the flow of energy in electrical power installations.

They are exclusively for supplying Eurotherm (or Eurotherm approved) servomotors.

Handling, installation, operation, and maintenance are only permitted under the conditions of and in keeping with the effective and/or legal regulations, regulation publications and this technical document.

**The operator must make sure that these regulations are strictly followed.**

### **Concept of the galvanic separation and insulation:**

Galvanically separation and insulation correspond to EN 50178/VDE 0160, amplified insulation.

**In addition** all digital signal inputs and outputs are galvanically separated either as a relay or via opto coupler. In this way an increased interference security and the limitation of damages in case of external incorrect connections is given.

The voltage level must not exceed the low safety voltage 60V DC or 25V AC, respectively in accordance with EN 50178/VDE 0160.

The operator must make sure that these regulations are strictly followed.

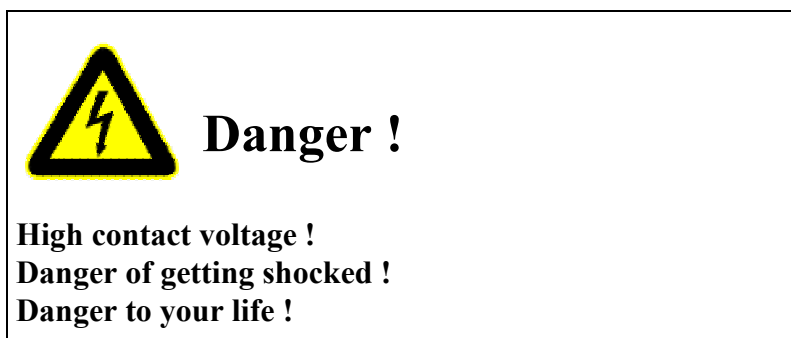

### **Caution !**

**Opening the servo drive by the operator is prohibited due to reasons of safety and guarantee. The requirement for problem-free operation of the servo drive is the expert configuring !**



## Safety precautions

### **Please observe !**

#### **Especially to be complied with:**

The class of protection which is permitted: protective grounding; operation is only permitted when the protective conductor is connected according to regulations.

The operation of servo drives is not allowed under the sole use of a residual current operated protective device as protection against indirect touching.

The servo drive may only be used in the rack or in its compact enclosure. Furthermore the regulator is designed solely for control cabinet operation.

Work on or with the servo drive may only be carried out with insulated tools.

Installation work may only be done in a deenergized state. When working on the drive, do not only block the Aktiv-input but separate the complete drive from the mains.

CAUTION - risk of electrical shock, wait 3 minutes after switching off, for discharging the capacitors.

Screws sealed with varnish fulfill an important protection function and may not be moved or removed.

It is prohibited to penetrate the inside of the unit with objects of any kind.

Protect the unit from falling parts (pieces of wire, fleys, metal parts, etc.) during installation or other work in the control cabinet. Metal parts can lead to a short in the servo drive.

Before putting into operation, remove additional covers so that the unit does not overheat. With measurements at the servo drive it is absolutely necessary to observe the potential separation!



## **Stop !**

Eurotherm Drives Limited is not liable for damages which occur by not following the instructions or the applicable regulations !!



# 1 General

## 1.1 System description

The digital servo drive serves to regulate the current, speed and position of **AC servo motors with resolver**.

All servo controls and functions are realized digitally.

### System variants

#### a) Standard - variants

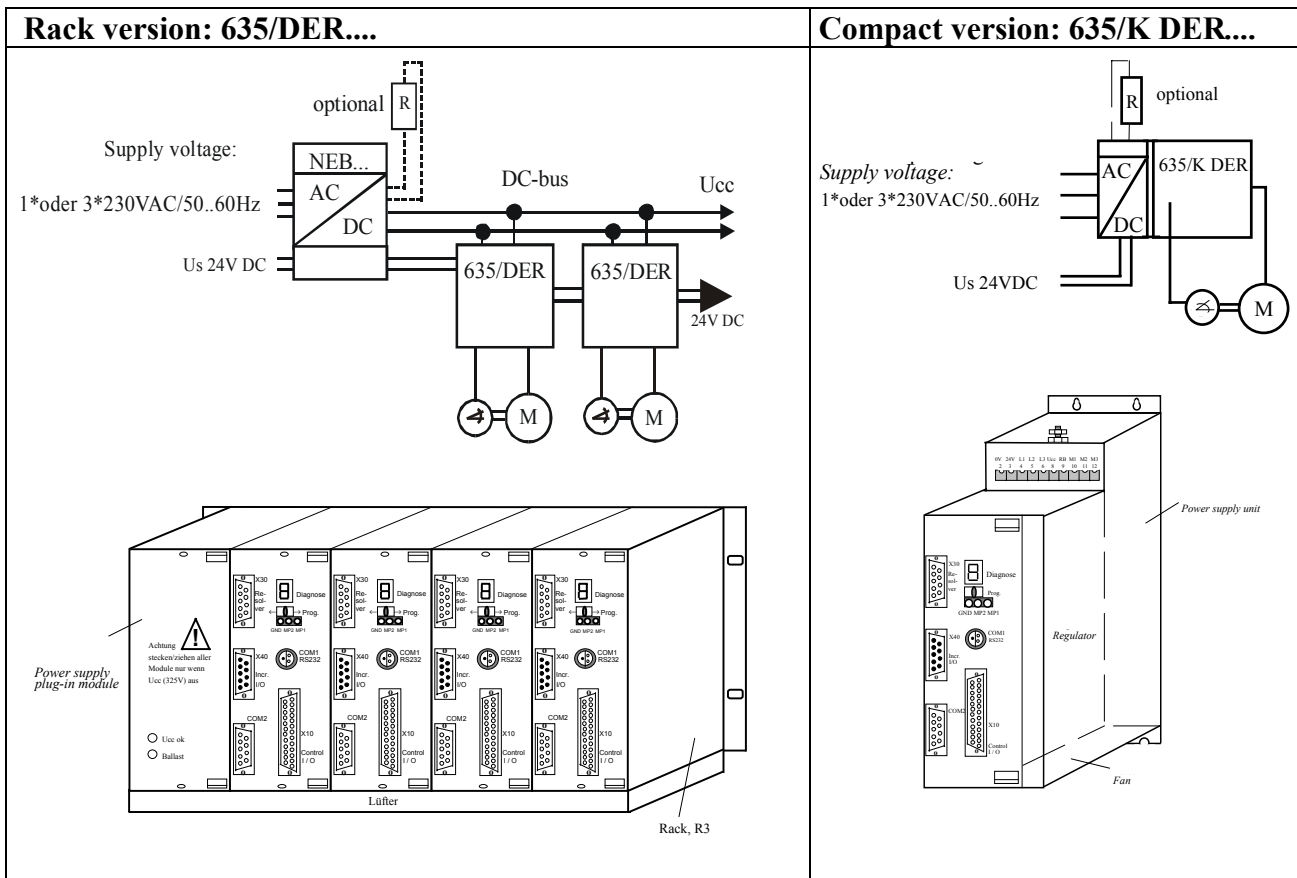

Explanations to rack and power supply modules are documented in separate description.

If required, the returned braking energy can be drawn off into additional external brake resistors.

The AC-supply voltage is fed directly or via transformer to the associated power supply module.

**The devices are designed to be operated on networks which are grounded on centre point (TN networks) !**

## System description

### System variants

#### b) Special - variants

Low-cost compact version: 635/L DER 03.A3	Modul with integrated power supply: 635/DER 01 oder 03 ..-N
<p>Without integrated fan and without brake resistor !</p>	<p>If required, the returned braking energy can be drawn off into additional external brake resistors.</p>

Explanations to rack and power supply modules are documented in separate description.

The AC-supply voltage is fed directly or via transformer to the associated power supply module.

**The devices are designed to be operated on networks which are grounded on centre point (TN networks) !**

#### c) Special design – variants

For example operation:

- DC motors with resolver
- DC motors with incremental encoder
- DC motors with tacho

**Information:** only on request!

## System description

### 1.1.1 Digital communication

#### Diagnosis

General: by 7-segment display  
 Comfortable: via PC by EASYRIDER (serial interface RS232)

#### Setup

Low Level: by Prog.-key on the front side

Comfortable: via PC by EASYRIDER (serial interface RS232)

#### Communication

The serial-communication-protocol is free documented.  
 (Explanation see separate documentation)  
 Every user has unrestricted access to all functions and parameters.

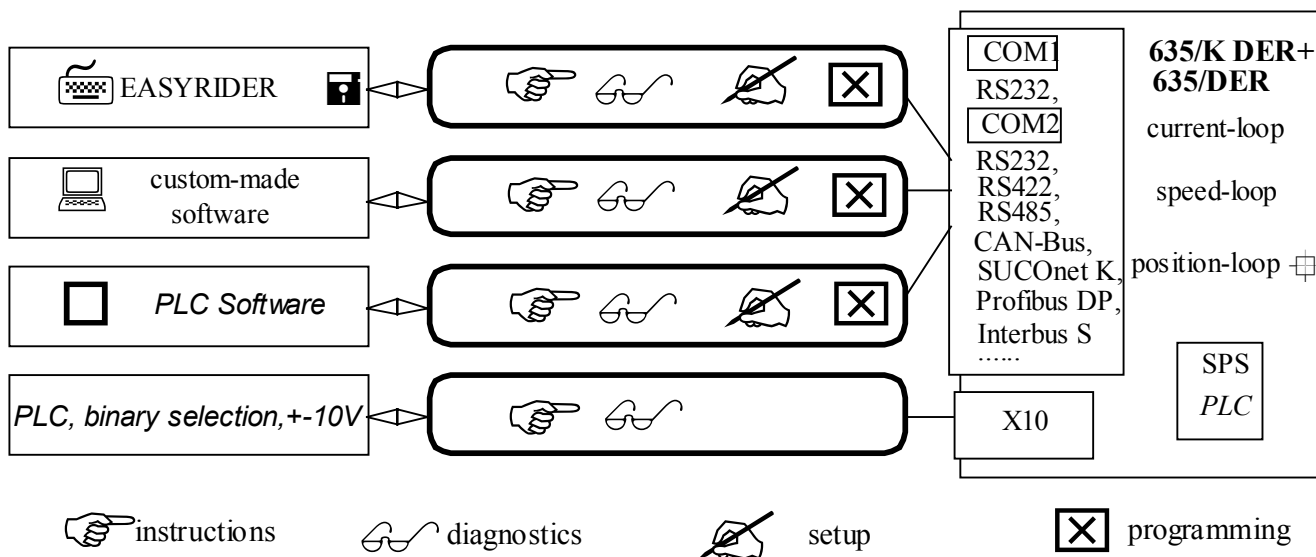

### 1.1.2 Operation configurations

The possibilities range from simple current and speed control to programmable position control processes (PLC) supported by the 1500 BIAS- command blocks.

#### refer to:

- Chapter 3 Operating modes
- Chapter 13.2 BIAS commands
- Chapter 13.3 Extended BIAS-commands



## System description

### 1.1.3 Compatibility to Eurotherm- 3 U analog regulator ESR AC S

(Not required for new projects)

The digital servo drives are to a great extent pin- and function compatible to the analog devices of the ESR AC S series.

The EASYRIDER  software allows the adaption to your existing equipment (**refer to:** Chapter 3 Operating modes)

Further adaptations can be done by solder-jumpers (**refer to:** Chapter 7.1 Jumper)

#### Compatibility restrictions:

Restriction
<b>1 External current limiting</b> due to analog input at X10.19 In the PC configuration menu the function speed regulator parameter (freely scaled) can be activated. In few cases the internal Pull-Up resistor with ESR AC S was loaded with an external Pull-Down resistor in order to reach a current limiting. The Pull-Up resistor on the DER+K DER can be activated via the solder strip <b>JP101</b> .
<b>2 Incremental encoder output-zero offset</b> With ESR AC S a zero drift was possible by means of DIP switch. This function is not realized with DER+K DER. Incremental signal with pulse interval.
<b>3 Temperature monitoring output T2</b> (only with ESR AC S with corresponding option circuit) T2 is no more signalized.
<b>4 Reference potential</b> all digital in- and output signals on X10 are referred to X10.9
<b>5 Temperature monitoring PTC</b> (only with ESR AC S with corresponding option circuit) Before switching off for approx 3 seconds "WARNING" is signalized.
<b>6 Reset</b> Connector X10.2 is no more assigned with reset function.
<b>7 n/I-Switch over</b> Connector X10.11 is not reference potential for n/I-switch over anymore, but X10.9.
<b>8 Warning</b> Connector X10.7 is not reference potential for warning output anymore, but X10.9.
<b>9 The max. operating voltage</b> on all signal outputs of X10 is DC 45V DC
<b>10 Pin 26 on X50</b> is not assigned internally and must be free !

One cannot completely rule out the possibility that with special designs of ESR AC S devices additional adjustments have to be made.

### 1.1.4 Compatibility to series APOLLO 2G

Output power supply +5V DC / 150mA for encoder via decoupling diode at X40.9.

Incremental signal with pulse interval.

#### Compatibility restrictions:

Furthermore, there are no compatibility restrictions.

## 1.2 Key to the models

Marking	Standard				optional		Sonder	
	a	b	c	d	e	f	g	
Model:	XXX/	X	DER	XX	.A3	-X	-XXX	-XX

Marking	Description
	XXX/ = 635 ≅ Eurotherm-design (blue)
<b>a</b>	K = Compact 1 axis servo drive system (is not used with model plug-in device) L = Low-cost compact design, only for 2,5A rated current !
<b>b</b>	DER = Digital Europe Regulator
<b>c</b>	Rated current: 01 = 1,0 amperes 03 = 2,5 amperes 05 = 5,0 amperes 07 = 6,5 amperes 10 = 10,0 amperes (only 3-phase)
<b>d</b>	.A3 = Regulator 3 rd generation
<b>e</b>	-N = with integrated power supply ≅ special, only module (rack) - design 1 phase (optional) -E = with EMC bow unit, only compact version -O = without integrated power supply ≅ standard
<b>f</b>	on the drive: additional communication via <u>COM2</u> -232 = RS 232 interface -422 = RS 422 interface -485 = RS 485 interface -CAN = CAN-bus -SUC = SUCOnet K -PDP = Profibus DP -IBS = Interbus S (+ 2 <sup>nd</sup> plug) -EA5 = I/O interface (5 Inputs, 2 Outputs)
<b>g</b>	-BS = moisture condensation protection -S = special setting (for example: Ballast input power) -X7 = Wide contact X10.7 – X10.8 -B7 = BS + X7

### 1.2.1 Example

Typical example of an order of a 1-axis compact device in Eurotherm design:

**Model:** 635/K DER 03.A3-E-CAN

- 635/ = Eurotherm-design (blue)
- K = Compact 1 axis servo drive system
- DER = Digital Europe Regulator
- 03 = 2,5 amperes
- .A3 = Regulator 3 rd generation
- E = with EMC bow unit
- CAN = CAN bus



## 1.3 Range data

### 1.3.1 Insulation concept

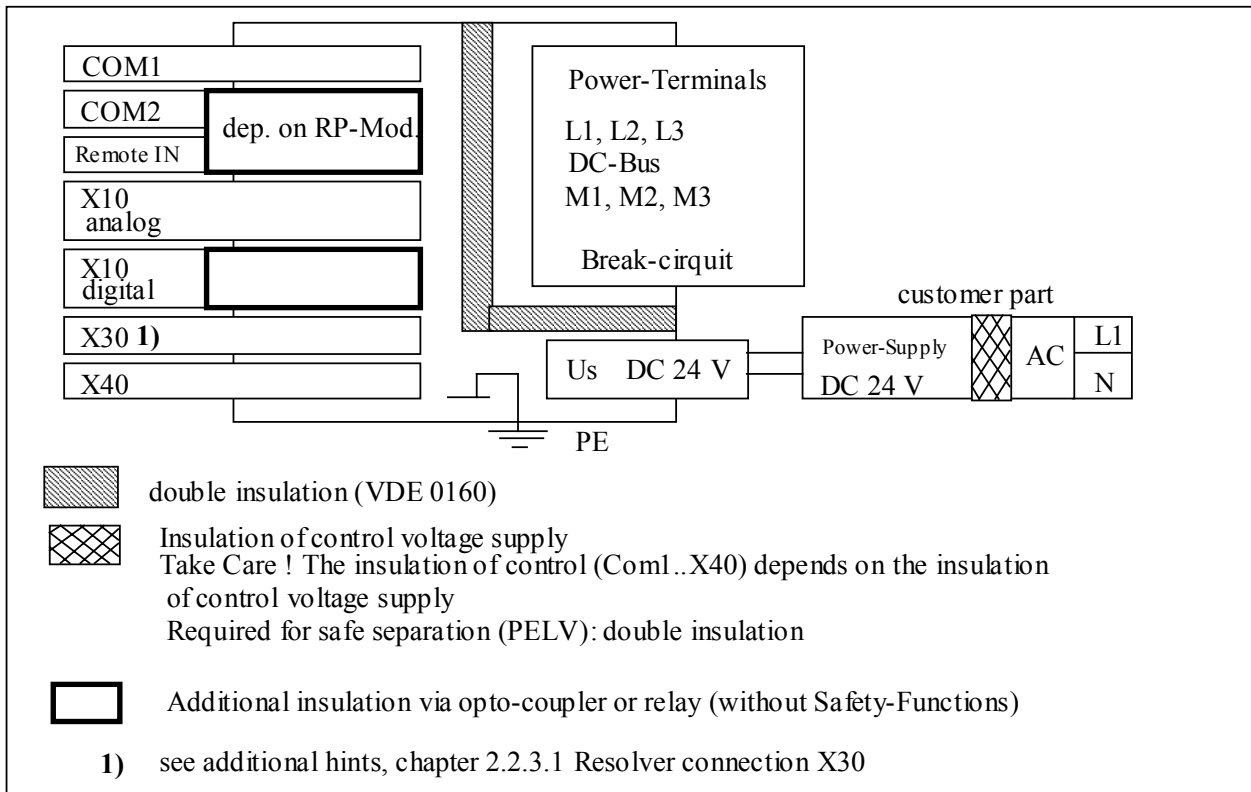

### 1.3.2 Generally data

Enclosure Rating (for mounting in cubicle)	IP20
operating temperature range	VDE 0160, Klasse 3K3
storage temperature range	-25°...+55° C
air pressure	86 kPa - 106 kPa
Humidity	5 % - 85% 40°C
Opertating Temp	0...40°C
reduced operation derating of the output current	>40°...< 50°C <sup>1)</sup> 2% /°C
Altitude h	h ≤ 1000m
reduced operation Derating of the output current	h > 1000...≤ 4000m <sup>1)</sup> 1% / 100m
Safety Overvoltage-category of power circuit	VDE 0160, UL, cUL III, VDE 0160
Pollution degree for mounting in cubicle	VDE / UL: 2
Vibration test in accordance with DIN IEC 68-2-6, test FC Condition for testing Frequency range Amplitude Acceleration Test time per axis Frequency sweep speed	10...57Hz 57...150Hz 0,075 mm 1g 10 Frequenzzyklen 1 Oktave/min

1) Use only fan-cooled devices. For reduced operating conditions, no UL-Approbation are available.

## Range data

### 1.3.3 Compact units 635/K DER

Compact Units			635/K DER 01.A3	635/K DER 03.A3	635/K DER 05.A3	635/K DER 07.A3	635/K DER 10.A3
<b>Input</b>							
Supply Voltage	min.	[V]	14				
	Un	[V]	230				
	max.		+ 10 %				
50..60 Hz							
Phases			1 / 3				3
Supply-preparation			Fuse ors, Filters, Contact <b>see:</b> chapter 5.6 Fuses, contactors, filters				
Power-on current limit	Typ		NTC 4 Ohm				
Supply for fan	Un AC	[V]	230V, f = 50/60 Hz, P = 12/10 W, 40/50 m³/h				
Control Voltage	<sup>1)</sup> Us	[V]	24 DC V +20% -10%, <b>attention:</b> chapter 1.3.1 isolation-conzept				
Control-Current	Is DC	[A]	Continuous: max 1,2A Power-On-Peak: nom. 3A; max 5A / 0,8 mS, 2,5A / 25mS				
<b>Output</b>							
Sinewave-Voltage at Un	Unr	[Veff]	220				
derating of Unr			depends on load and single-or 3-phase supply. <b>see:</b> chapter 1.3.5 Single-or 3-phase supply				
Rated Current RMS	Inr	[A]	1	2,5	5	6,5	10
Max Current RMS	Imax	[A]	2	5	10	10	20
min. time for Imax		min.	5 Sec	5 Sec	5 Sec	5 Sec	5 Sec
Min motor inductance (between terminals)	Lmot	[mH]	9,6	4,8	2,4		1,2
<b>Brake-Circuit</b>							
Setpoint DC	Ub	[V]	376				
Max Power	Pbp	[kW]	5,5				7,5
Cont. Power	Pbd	[W]	130				
Internal Resistor	Rbint	[Ω]	100				
	Pd	[W]	30				
	Pmax	[kW]	1,4				
Min. external Resistor	<sup>2)</sup>	[Ω]	33				20
<b>General</b>							
Fan - model	<sup>2)</sup>		L 230 / 16TE * 38				L 230 / 18TE * 25
Power-losses							
	Fan, Electronic	[W]	30				
Powerstage per A		[W/A]	9				
Weight		[kg]	2,75			2,90	3,45
Further data			<b>see:</b> chapter 11 General technical data				

<sup>1)</sup> suggested: transformer-based supply

<sup>2)</sup> use only Eurotherm-released types



## Range data

### 1.3.4 Plug-in modules 635/DER

Plug-in modules			635/DER 01.A3	635/DER 03.A3	635/DER 05.A3	635/DER 07.A3	635/DER 10.A3
<b>Input</b>							
DC-Bus rated	min.	[V]	20				
	U <sub>g</sub>	[V]	325				
	max.		+ 10 %				
Control Voltage	<sup>1)</sup> U <sub>s</sub>	[V]	24 DC V +20% -10%				
			<b>attention:</b> chapter 1.3.1 isolation-conzept				
Control-Current	<sup>1)</sup> I <sub>s</sub> DC	[A]	Continuous: max 1,2A Power-On-Peak: nom. 3A; max 5A / 0,8 mS, 2,5A / 25mS				
Fan	<sup>2)</sup> Typ				L220K 230V AC, P = 20W		
<b>Output</b>							
Sinewave-Voltage at Un	Unr	[V <sub>eff</sub> ]	220				
Derating of Unr			depends on load and single-or 3-phase supply <b>see:</b> chapter 1.3.5 single-or 3-phase supply				
Rated Current RMS	I <sub>nr</sub>	[A]	1	2,5	5	6,5	10
Max Current RMS	I <sub>max</sub>	[A]	2	5	10	10	20
Min. time for I <sub>max</sub>		min.	5Sec	5Sec	5Sec	5Sec	5Sec
Min motor inductance (between terminals)	L <sub>mot</sub>	[mH]	9,6	4,8	2,4	1,2	
<b>Brake-Circuit</b>							
Setpoint DC	U <sub>b</sub>	[V]	376				
Max Power	P <sub>bp</sub>	[kW]	5,5				7,5
Cont. Power	P <sub>bd</sub>	[W]	130				
Min. external Resistor	<sup>2)</sup>	[Ω]	24				20
<b>General</b>							
Power-losses							
Fan, Electronic		[W]	20				
Powerstage per A		[W/A]	9				
Weight		[kg]	0,75			0,90	1,20
Further data			<b>see:</b> chapter 11 General technical data				

<sup>1)</sup> suggested: transformer-based supply

<sup>2)</sup> use only Eurotherm-released types



## Range data

### 1.3.5 Single- and three-phase supply

Due to the line-ripple of DC-Bus, the rate of usable output voltage is derated like follows. This deration effects the max. reachable speed of the applied motor.

#### Three-phase-supply:

the unloaded output voltage will be derated to approx. 90%, maximum 85 %

#### Single-phase supply:

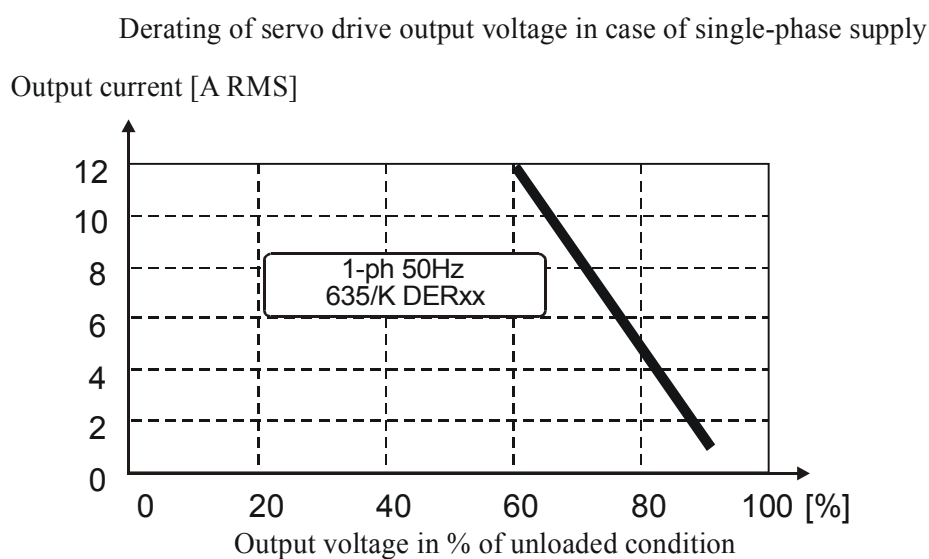

#### Hints for setup:

To avoid unexpected tripping of undervoltage threshold (EASYRIDER ) , this value should be set to default.

Required motor-terminal-voltage for specified speed.

Approximation: (up to 3000 RPM)

$$U_{kl} = 1,2 * (EMF * n / 1000) + I * (R_{ph} + R_L) [V]$$

$U_{kl}$  required motorvoltage [V RMS]

EMF Back-EMF of motor [V RMS] / 1000 RPM

$R_{ph}$  resistance of motor (between terminals) [ $\Omega$ ]

$R_L$  line resistance of motor cable [ $\Omega$ ]

$I$  motor-current [A RMS]



## Range data

### 1.3.6 Output power

In case of continuous operation in the range of full-load the limits like shown in the diagram have to be respected. Typical servo applications are not effected by this restriction.

(S3-operation: Start/Stop)

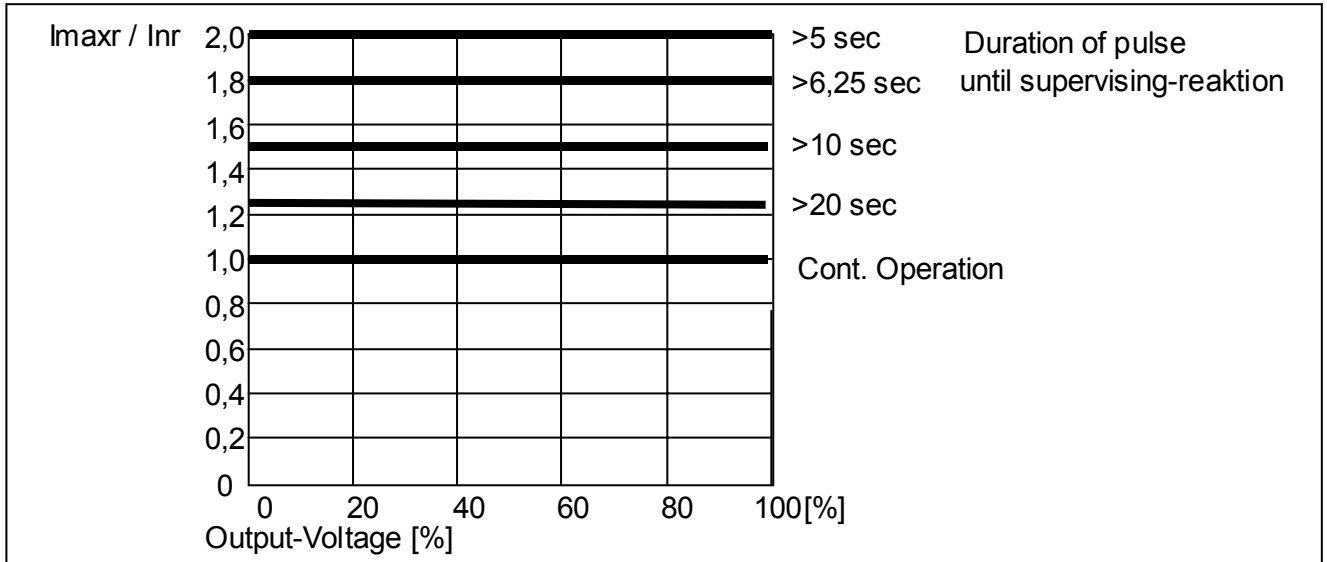

### 1.3.7 Rated current / max. current – period

Guaranteed minimum requirements value I<sup>2</sup>T- work load  
Series 631/5/7

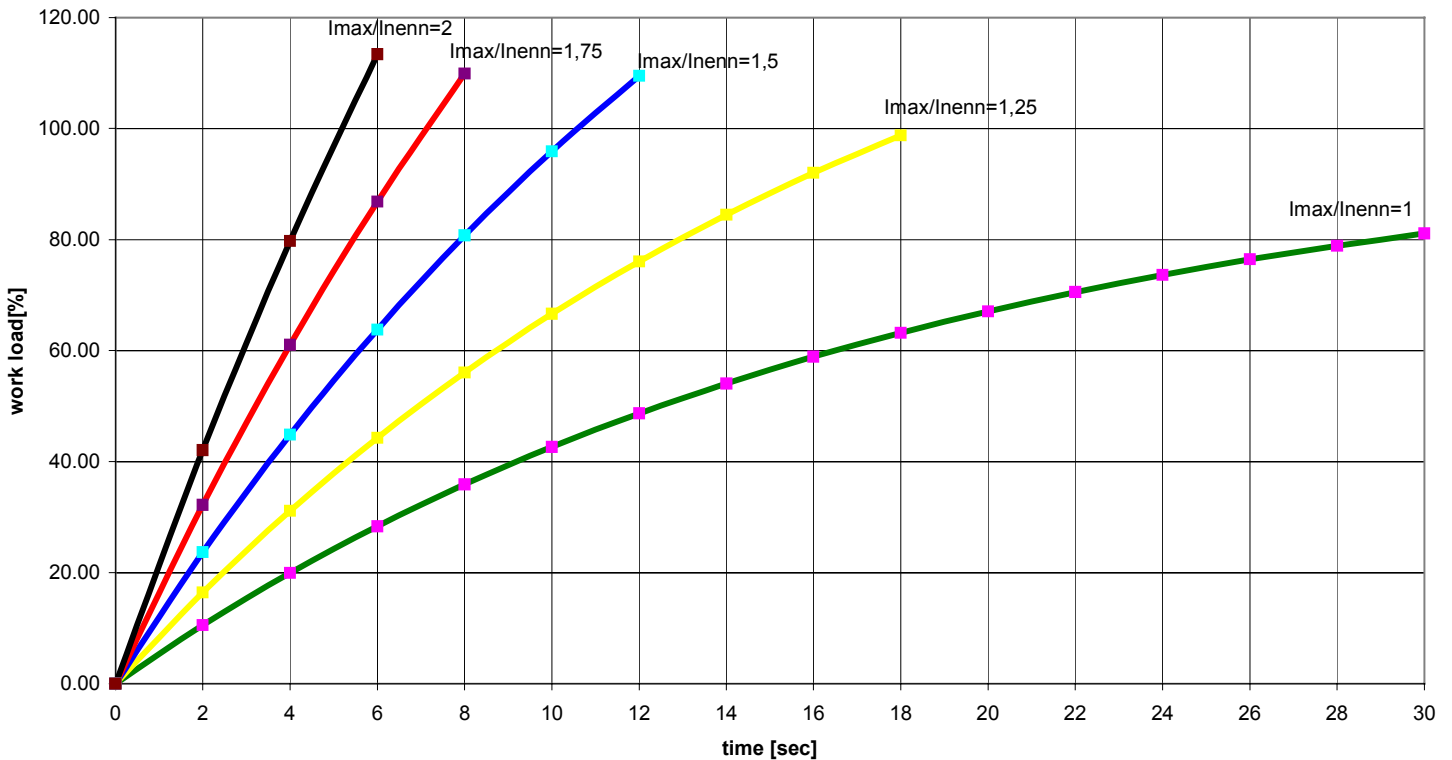

## 1.4 Dimensions and layout

### 1.4.1 Dimensions for compact device and plug-in module

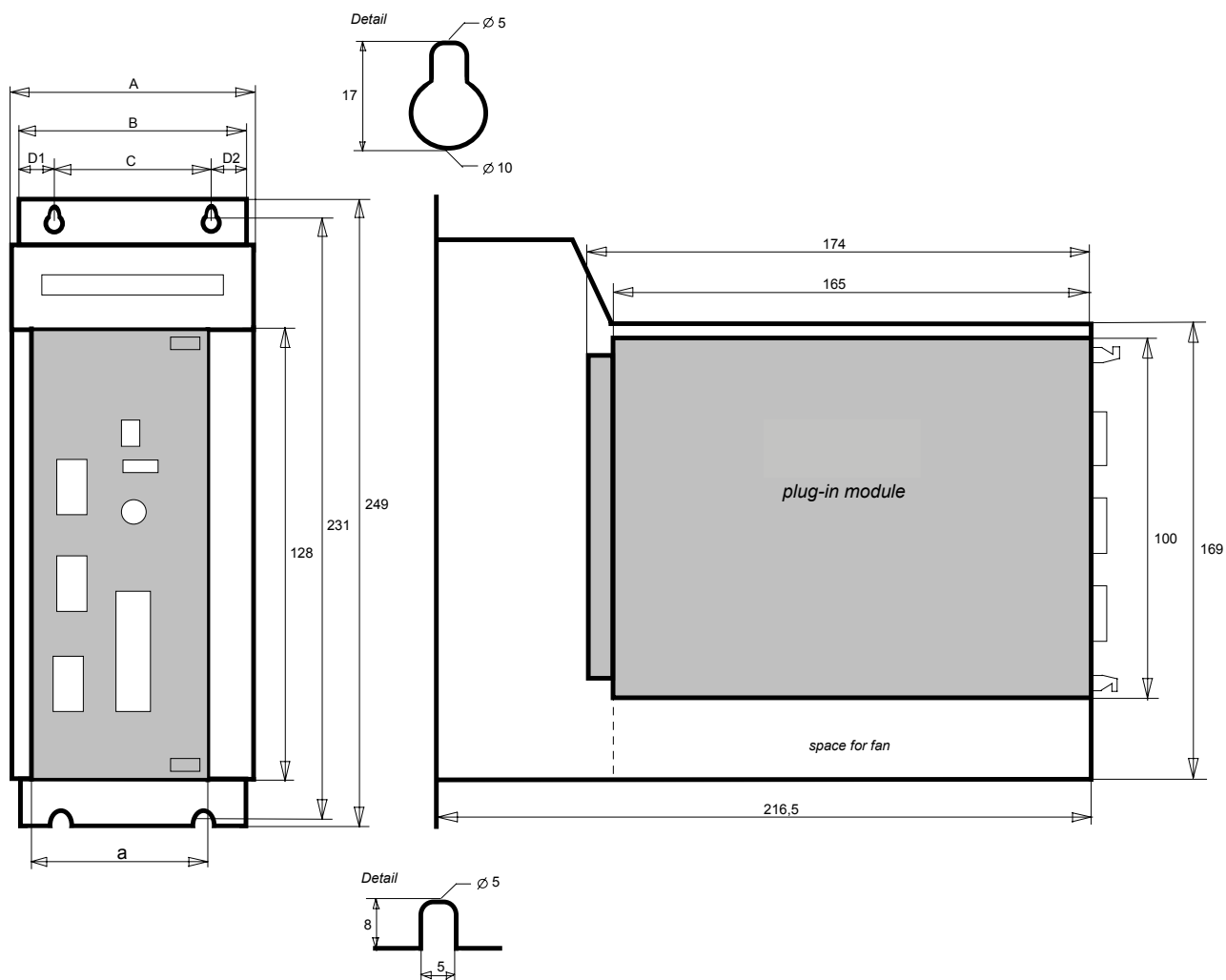

	635/K DER 01...05 635/L DER 01...03	Width	635/K DER 07	Width	635/K DER 10	Width
A*	84,0 mm	18 TE	84,0 mm	18 HP	99,0 mm	21 HP
B	81,0 mm		81,0 mm		95,5 mm	
C	44,0 mm		44,0 mm		44,0 mm	
D1	18,0 mm		18,0 mm		15,0 mm	
D2	18,0 mm		18,0 mm		37,0 mm	
a	60,0 mm	12 TE	72,0 mm	15 HP	91,4 mm	18 HP

1 HP ≈ 5,08mm

A\* with enclosure in white, occurred additional measure of screw heads approx. 2 x 3mm = 6mm

#### **Important:**

Make sure you leave an additional space of approx. 70 mm on the front side for the signal mating plugs !



## Dimensions and layout

### 1.4.2 EMC bow (optional)

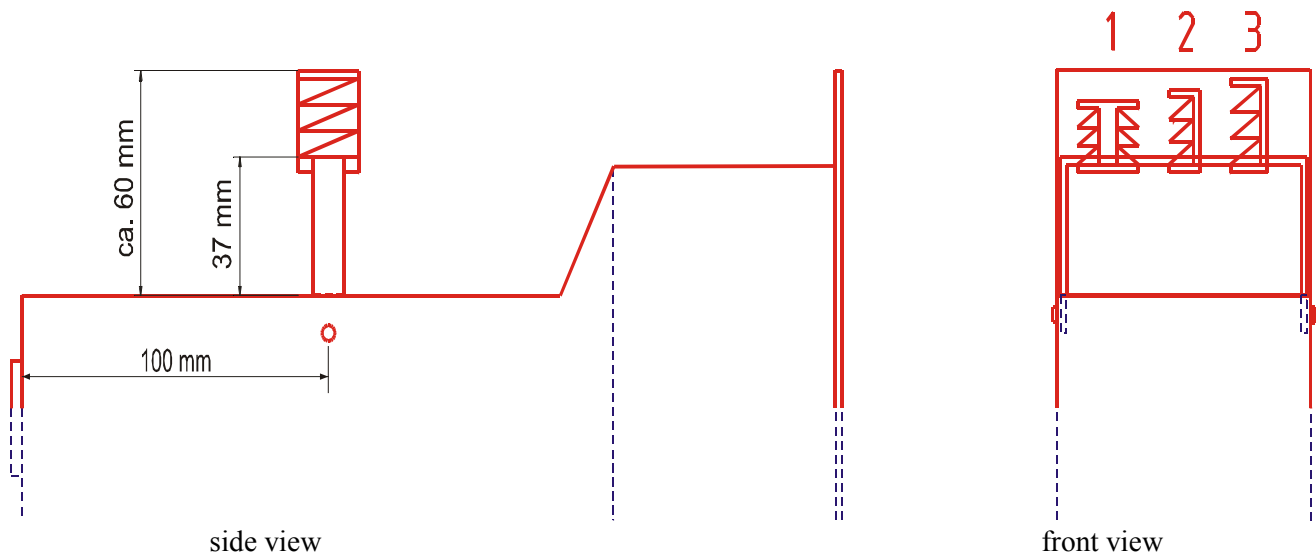

EMC bow for	
Resolver cable	1
Mains cable	2
Motor cable	3

meaning:

1,2,3 = cage clamp terminal

## Dimensions and layout

### 1.4.3 Layout

#### 1.4.3.1 Layout of controller board

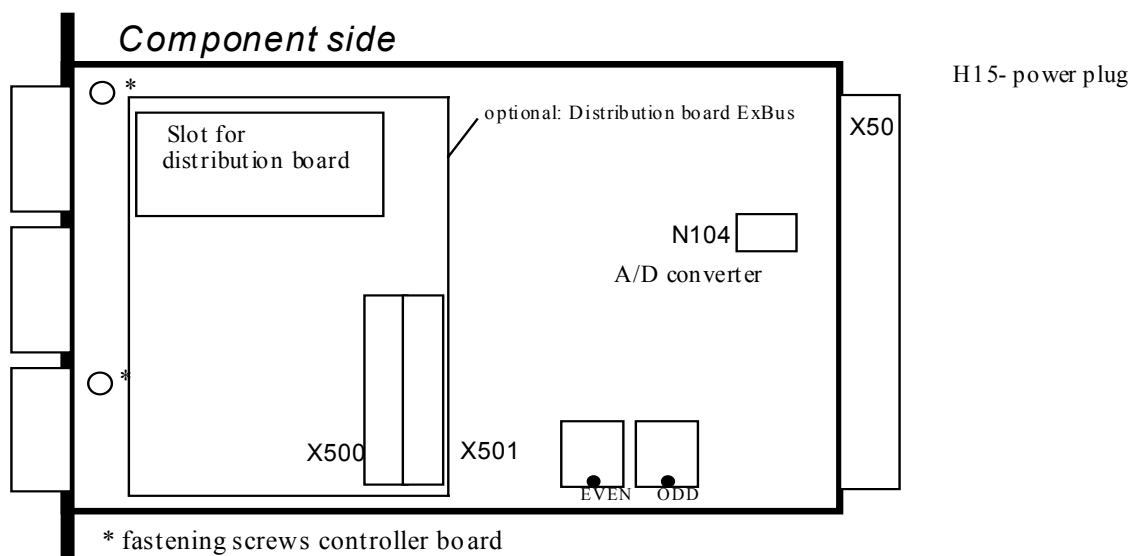

#### **Note:**

The configuration modules can only be reached after removing the plugs.

#### 1.4.3.2 Layout of power board

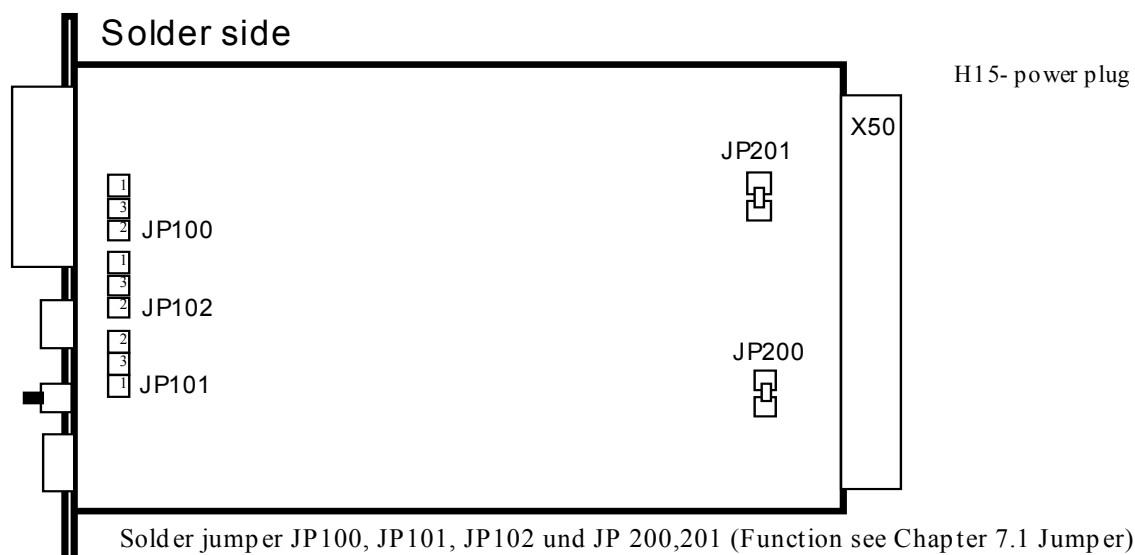



## 2 General view of connections

### 2.1 of the compact device 635/K DER 01...10

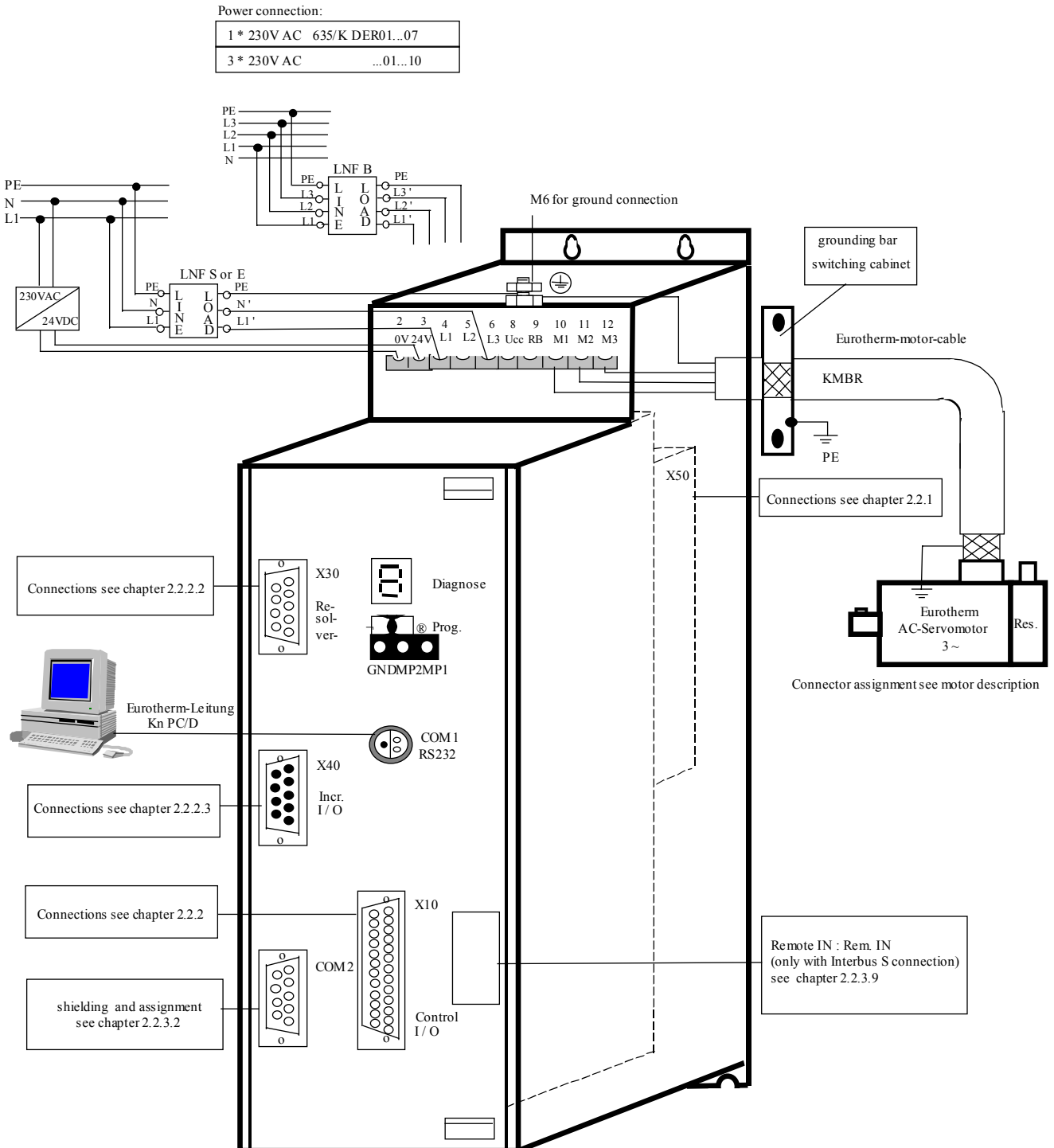

## 2.2 Connector pin assignments and contact functions

### 2.2.1 Power connections for plug-in module 635/DER standard at the rear of the rack (H15-multiple pin strip according to DIN 41612)

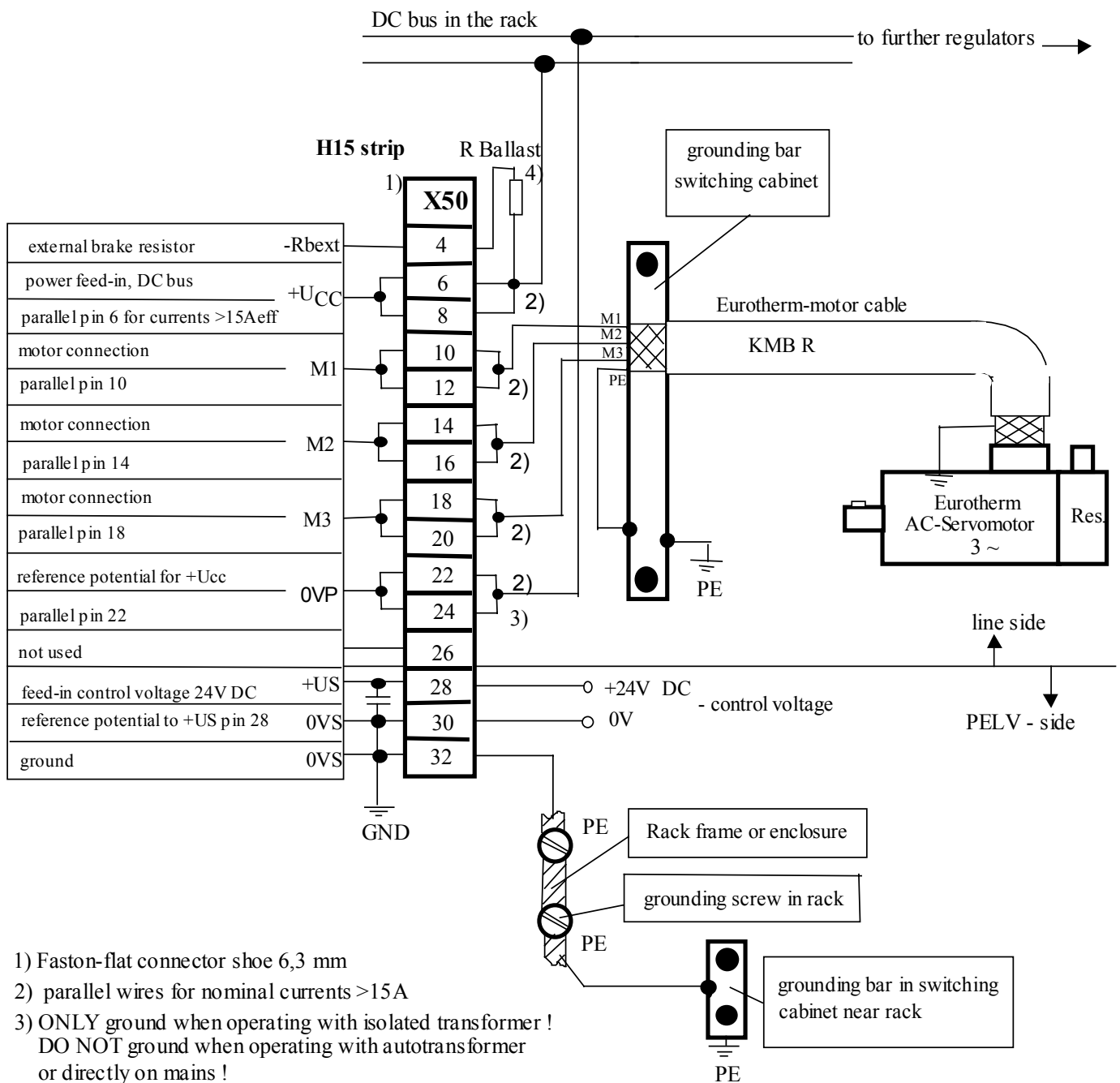

## Connector pin assignments and contact functions

### 2.2.1.1 for plug-in module 635/DER ...-N (with integrated power supply) special at the rear of the rack (H15-multiple pin strip according to DIN 41612)

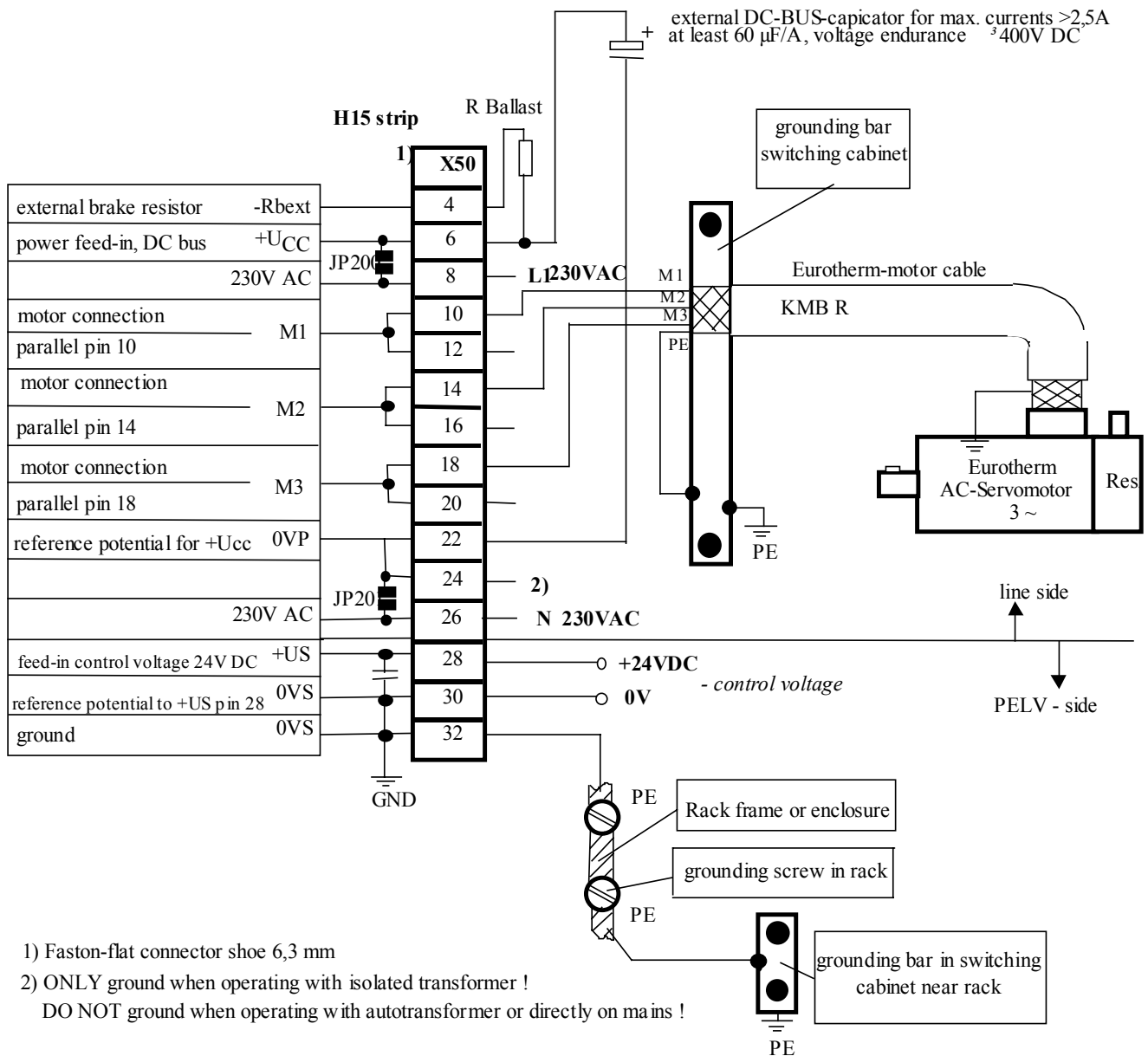

1) Faston-flat connector shoe 6,3 mm

2) ONLY ground when operating with isolated transformer !

DO NOT ground when operating with autotransformer or directly on mains !

#### Note:

Around an interchanging to the standard module (without integrated power supply) guarantee, the coding is broken out " D " at the H15-multiple pin strip.

In the scope delivery is a coding-pen, you can coding the "customer" H15-multiple pin strip.



## 2.2.2 Signal connections

### 2.2.2.1 Control signal plug X10 SUB D25 socket

#### Complete representation

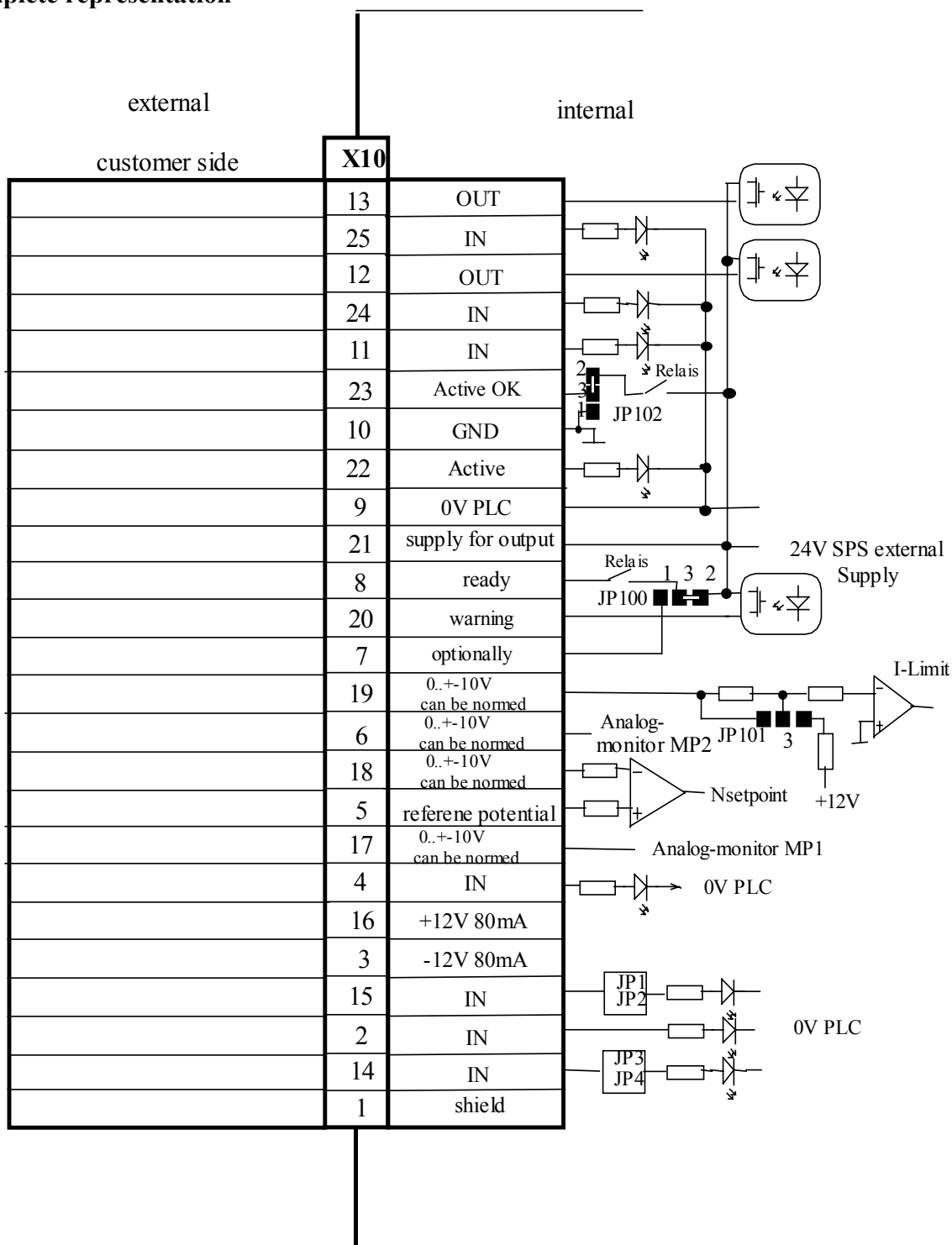

# Signal connections

## Control signal plug X10

### SUB D25 socket

### Connection example

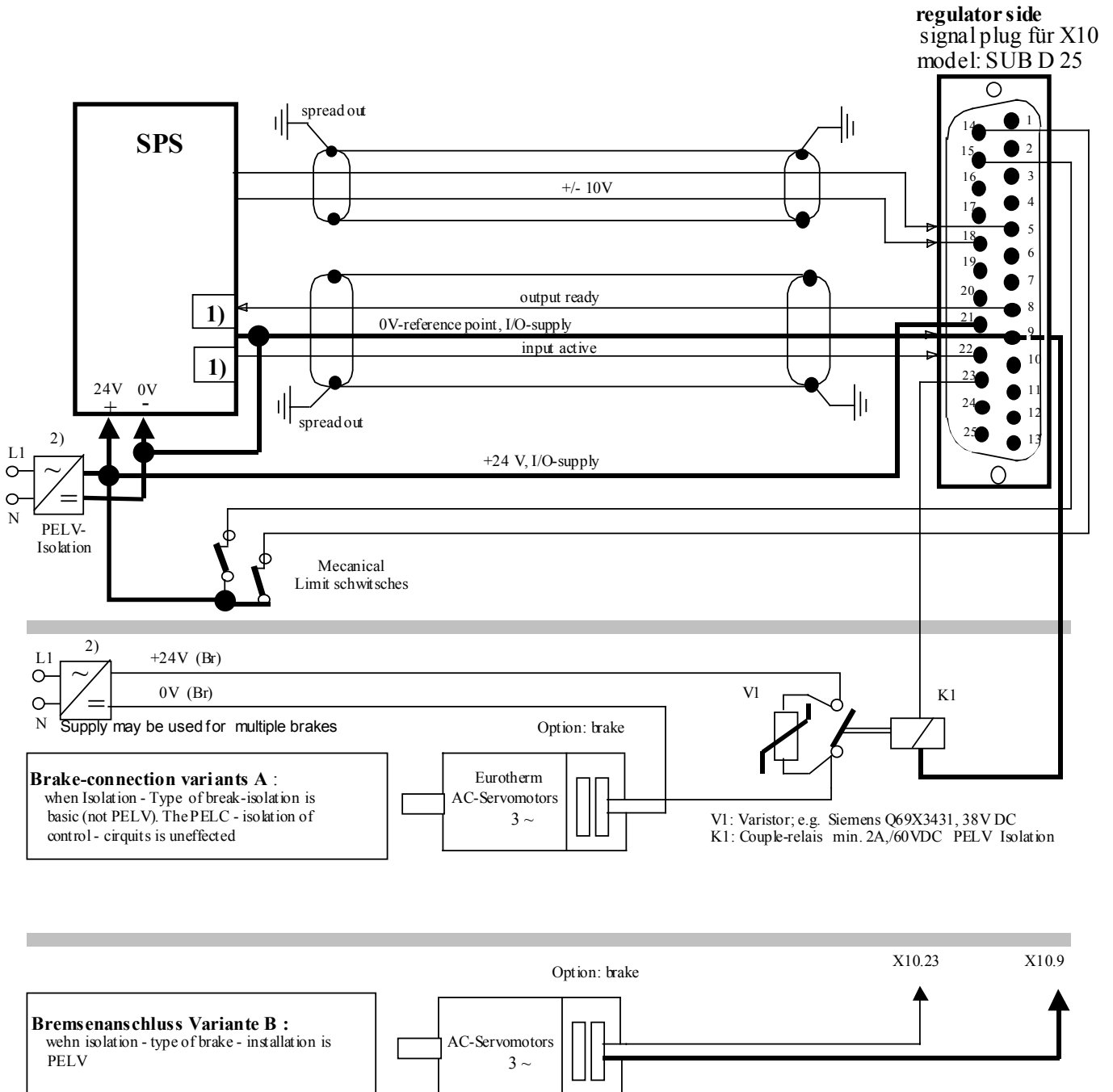

1) Security- and supervising logic, to be programmed by user !

2) **IMPORTANT:**

The Power-Supply for the Motor-Brake has to be adapted to the type of Brake. Voltage-Drops caused by long cables also may effect malfunctions of the Brake

**Signal connections**  
**Control signal plug X10**  
**SUB D25 socket**

**Inputs / outputs**

PIN	Function	Type	In- /Output
1	shield connector		shield
2	configurable (chapter 3)	OPTO	input
3	stabilized auxiliary voltage -12VDC; max. 80 mA		output auxiliary voltage
4	configurable (chapter 3)	OPTO	input
5	Reference point to X10.18		analog input 0...+10V Ri = 10 kOhm
6	Current monitor can be scaled in the speed controller menu		analog output, Signal from test socket MP2
7	via JP100 (solder jumper) can be assigned as free and loopable potential of the READY contact		optional
8	ON: regulator without fault OUT: regulator fault or supply voltage off	Relais	output fixed: ready
9	Reference point for digital inputs		Reference point for digital inputs
10	Reference potential for analog signals		ground
11	configurable (chapter 3)	OPTO	input
12	configurable (chapter 3)	OPTO	output
13	configurable (chapter 3)	OPTO	output
14	configurable (chapter 3)	OPTO	input
15	configurable (chapter 3)	OPTO	input
16	stabilized auxiliary voltage +12V DC; max 80 mA		output auxiliary voltage
17	actual speed value monitor, scalable		analog output signal from test socket MP1
18	nominal speed value; scalable differential referenced to X10.5		analog input 0...+10V Ri = 10 kOhm
19	Setting of the current limit can be activated and scaled (0..+10V for 0.. I <sub>max</sub> )		analog input 0..+10V Ri = 10 kOhm
20	configurable (chapter 3)	OPTO	output
21	Nominal: 24V DC		Supply for outputs
22	H = output stage is active L = output stage inactive	OPTO	input fixed: active
23	configurable (chapter 3)	Relais	output
24	configurable (chapter 3)	OPTO	input
25	configurable (chapter 3)	OPTO	input

Data of the digital inputs and outputs see chapter 11



## 2.2.3 Resolver

### Functions of the resolver evaluation

Formation of a digital value for the rotor position within one revolution, evaluation: 12 or 14 bit; adjustable in the config. menu EASYRIDER.

#### derived from this:

- commutation according to pole pair number
- actual speed value
- incremental position output
- position value for position regulation

It is only allowed to use Eurotherm approved resolver

#### 2.2.3.1 Resolver connections X30 SUB D 09 socket

### Resolver connector

**motor side**

Eurotherm - motor size 0...4

Model: AC G, AC R, AC M<sub>n</sub>, AC M<sub>2n</sub>

**regulator side**

Eurotherm - servo drives

Model: 631/635 and 637/637+

view solderside

view solderside

SIR ST.0200.0001	KIR-B KA.0003.6301		SUB - D 09 S/M ST.1002.2001
PIN - Nr.	colour	function	PIN - Nr.
1	white	sin +	4
2	brown	sin -	8
3	green	cos +	3
4	yellow	cos -	7
5	red	PTC optional <sup>1)</sup>	2
6	blue	PTC optional <sup>1)</sup>	6
7	pink	carrier -	9
8	gray	carrier +	5
case		screen	1 and case

<sup>1)</sup> **Attention ! Security and insulation:**  
 The temperature sensor in the motor winding must be insulated for secure division (PELV).  
 Otherwise, the insulation class of the drive becomes reduced or the effort of an additional galvanic separation is required.

 <b>EUROTHERM ANTRIEBE</b>				<b>Maßstab / scale:</b> Typ / model: KK RT GMR-xx.x/B	
	Bear. 09.05.01 Gep. 10.05.01 Norm	DL EH	<b>Bezeichnung / designation:</b> Blue resolver cable for Eurotherm standard motors and servo drives		
<b>Zeichnungsnummer / drawing No:</b> Z-RK.6300.xxxx					Blatt sheet 1
Zust.	Änderung	Datum	Name	Ursprung	Dateiname / File name: Z-RK.6300.xxxx_E.cdr

## 2.2.4 Multifunction X40

### Description X40

Via a programmable I/O processor, the X40 can be configured different. (EASYRIDER )

Standard functions:

- Incremental output
- Incremental input
- Stepper motor - pulse input

The different configuration creates e.g. ideal conditions for synchronous applications..

General data	X40
Plug model:	SUB D 09 plug
maximum input or output frequency:	200 kHz
maximum cable length connected to galvanical insulated terminals (Encoder, controls)	25 m; for extended distances please contact our engineer
maximum cable length connected to ground-related terminals (other drives, controls)	2 m, take care for good common grounding !
maximum number of signal inputs to one as incremental-output configured device	8
output signals:	driver model MC34C87 or compatible, RS422
differential logic level:	$L \leq 0,5V$ $H \geq 2,5V$
nominal range:	0,0 ... 5,0V
input signals:	receiver model MC34C86 or compatible, RS422
differential input level:	diff min = 0,2V
nominal range:	0,0 ... 5,0V
nominal signal difference:	1,0V
current consumption:	1...4 mA (depending on frequency)

#### **Notice:**

Master / Slave operation

1 Master maximum 8 Slaves

Condition: Devices directly side by side !



## Multi-function X40

### 2.2.4.1 Incremental output

Connector pin assignment X40

EASYRIDER  X40 mode = 00

- Incremental encoder simulation for processing in positioning modules
- Standard: 1024 increments  
further selectable pulse numbers: 512, 256, 128

Parameter area of the input signals:

10...1000000 increments

Pin	Function	Designation
1	Channel B	B
2	Channel B inverted	/B
3	Shield connector	Shield
4	Channel A	A
5	Channel A inverted	/A
6	Reference potential to pin 9	0 VS
7	Channel Z inverted zero impulse	/Z
8	Channel Z, zero impulse	Z
9	Supply voltage output max. 150 mA	+ 5 VDC

#### Design rule:

The capability of input-frequency of any connected device must meet at least the value of pulse outputs on X40.

n = max. speed (rpm)

x = increments e.g. 1024

f = output frequency at X40.1,2,4,5

Formula:  $f = \frac{1,2 * (n * x)}{60} = [\text{Hz}]$

Example: n = 4000 rpm

$f = \frac{1,2 * (4000 * 1024)}{60} = 81920 \text{ Hz}$

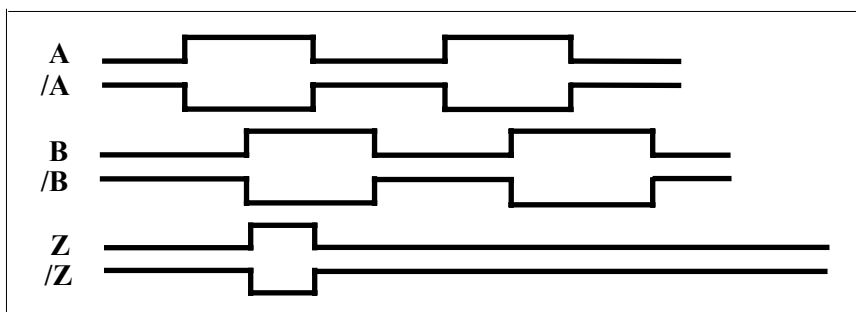

Incremental Outputs

## Multi-function X40

### 2.2.4.2 Incremental input

EASYRIDER  X40 mode = 1

Parameter area of the input signals:

10...1000000 increments

Pin	Function	Designation
1	Channel B	B
2	Channel B inverted	/B
3	Shield connector	Shield
4	Channel A	A
5	Channel A inverted	/A
6	Reference potential for pin 9	0 VS
7	Channel Z inverted zero impulse	/Z
8	Channel Z, zero impulse	Z
9	Supply voltage output max. 150 mA	+5 VDC

#### **Note:**

The operation of incremental encoders via long cables may cause a voltage drop of the encoder power supply. We suggest the use of external supply if necessary.

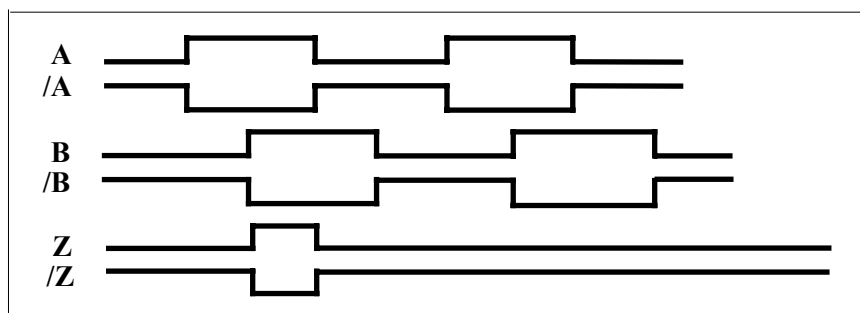

Incremental Inputs



## Multi-function X40

### 2.2.4.3 Stepper motor input

pulse / direction

EASYRIDER  X40 mode = 2

Pin	Function	Designation
1	output: drive active inverted	/READY
2	output: drive active	READY
3	Shield connector	Shield
4	Pulse inverted	/P
5	Pulse	P
6	Reference potential	GND
7	Direction inverted	/R
8	Direction	R
9	Supply voltage output max. 150 mA	+5 VDC

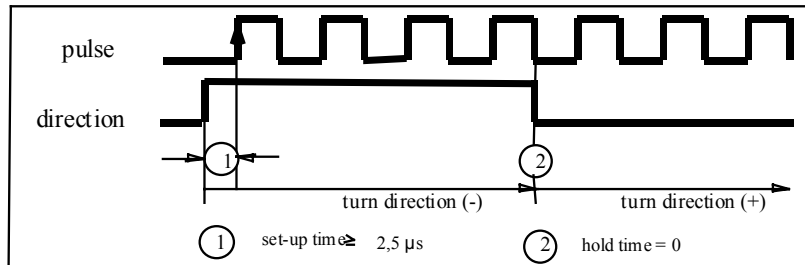

### 2.2.4.4 Stepper motor input

pulse positive / negative

EASYRIDER  X40 Mode = 3

Pin	Function	Designation
1	output: drive active inverted	/READY
2	output: drive active	READY
3	Shield connector	Shield
4	Pulse direction (-) inverted	/P-
5	Pulse direction (-)	P-
6	Reference potential	GND
7	Pulse direction (+) inverted	/P+
8	Pulse direction (+)	P+
9	Supply voltage output max. 150 mA	+5 VDC

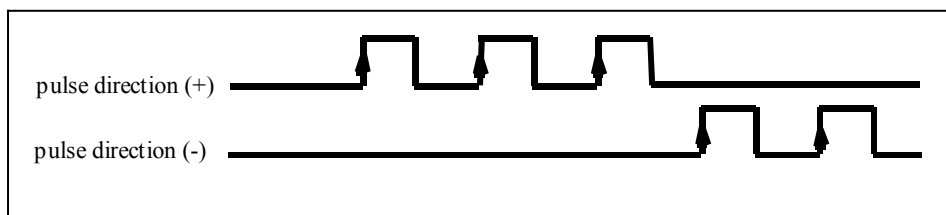



## 2.2.5 Digital interfaces

Service interface **COM1** (RS232))

### Standard

Functions:

- Supporting all diagnosis and setup tasks
- Connection to your PC is made with the Eurotherm communication cable KnPC/D
- Communication is made via the Eurotherm operating program (EASYRIDER )

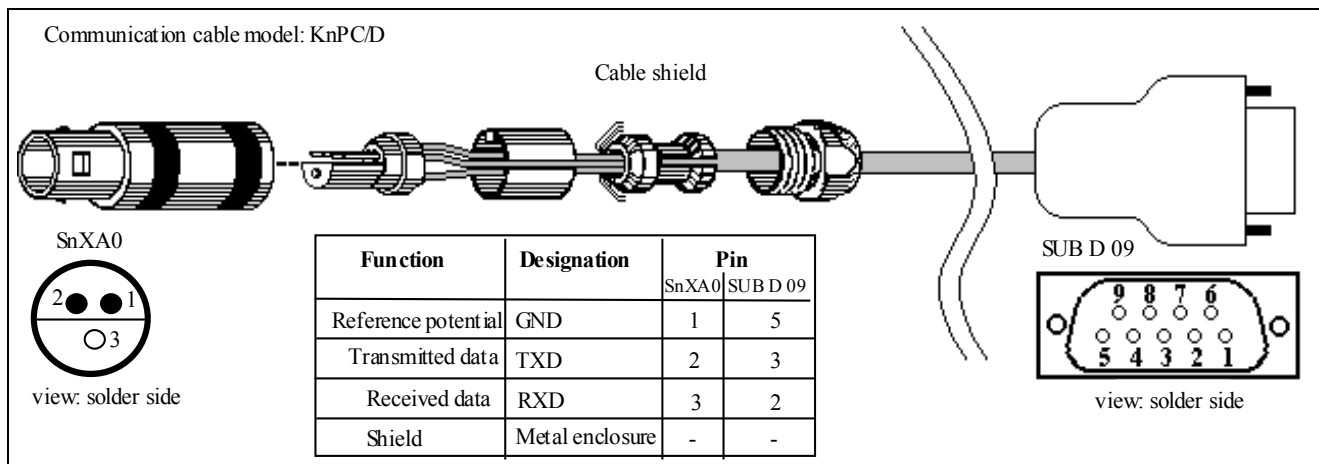

### **Notice:**

The service interface RS232 is not galvanically separated and should not be planned for this reason as a operating interface ("firm wiring")!



## Digital interfaces

### 2.2.5.1 Fieldbus interface COM2

Configuration interface  
(SUB D09 socket)

Many different functions can be implemented using **optional configuration interfaces**  
Layout, see chapter 1.4.2

#### Overview:

Interface designation	Interface	galvanic separation	design
RP 232	RS 232	-	A
RP 422	RS 422/485	-	A
RP 485	RS 422/485	X	A
RP CAN	CAN	X	A
RP PDP	Profibus DP	X	B
RP SUC	SUCOnet K	X	B
RP IBS	<sup>1)</sup> Interbus S	X	B

<sup>1)</sup> additional plug Rem. IN (SUB D)

### 2.2.5.2 additional In-/Outputs

Interface designation	Inputs	Outputs	Connection via	design
RP EA5	<sup>2)</sup> 5	2	COM2	C

<sup>2)</sup> no Fieldbus possibility (Interface)

#### Caution:

The connections COM2 and X30 are implemented via SUB D09 socket.  
The customer has to be guaranteed that an interchanging is not possible!

### 2.2.5.3 Interface – design

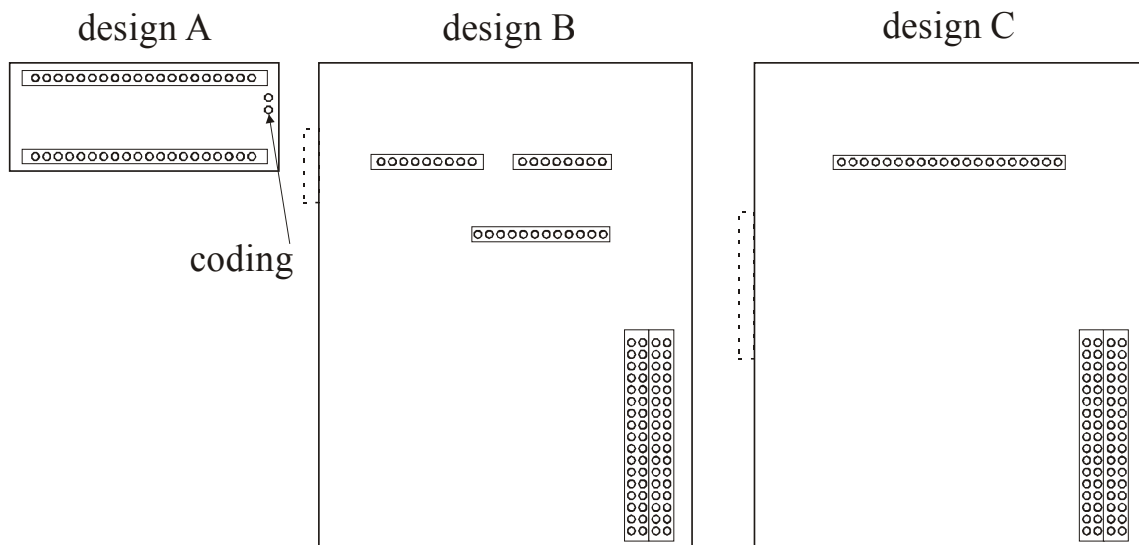

## Digital interfaces

### 2.2.5.4 Pin assignment for RS232 with configuration board RP 232

Pin	assignment as RS232
1	-
2	RXD
3	TXD
4	-
5	GND
6	-
7	-
8	-
9	-

design A

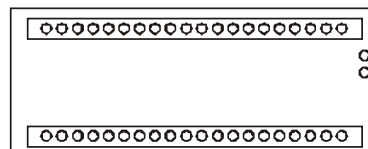

### 2.2.5.5 Pin assignment for RS422/485 with configuration board RP 422 without galvanic separation with configuration board RP 485 with galvanic separation

Pin	assignment as RS422/485
1	-
2	-
3	-
4	Data In
5	GND
6	Data In invertiert
7	Data Out invertiert
8	Data Out
9	-

design A

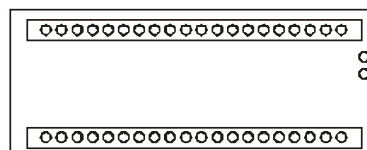

Daisy-chain wiring up to 16 devices



## Digital interfaces

### 2.2.5.6 Pin assignment for CAN

with configuration board **RP CAN**, with galvanic separation

Pin	Description	Designation
1	-	-
2	CAN_L bus line (dominant low)	CAN_L
3	Ground	GND
4	-	-
5	-	-
6	Ground	GND
7	CAN_H bus line (dominant high)	CAN_H
8	-	-
9	-	-

design A

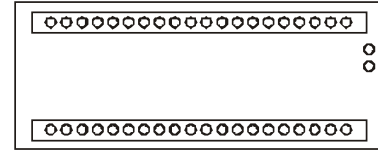

### 2.2.5.7 Pin assignment for Profibus DP

with configuration board **RP PDP**, with galvanic separation

Pin	Description	Designation
1	-	-
2	-	-
3	Line B	B
4	Request to send	RTS
5	Ground	GND
6	Potential +5V	+5V
7	-	-
8	Line A	A
9	-	-

design B

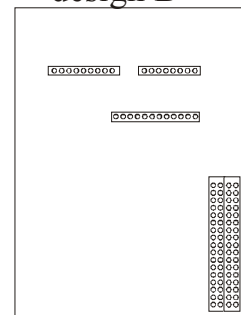

### 2.2.5.8 Pin assignment for SUCOnet K

with configuration board **RP SUC**, with galvanic separation

Pin	Description	Designation
1	-	-
2	-	-
3	Data line +	TA/RA
4	-	-
5	Signal ground	SGND
6	-	-
7	Data line -	TB/RB
8	-	-
9	-	-

design B

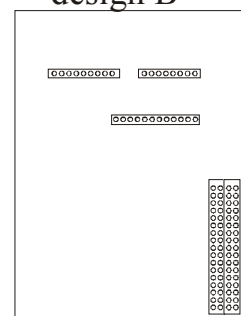

## Digital interfaces

### 2.2.5.9 Pin assignment for Interbus S

with configuration board **RP IBS**, with galvanic separation

#### Remote OUT (COM2)

Remote OUT (SUB D09 socket)

Pin	Description	Designation
1	Data line OUT forward (error voltage A)	DO2
2	Data line IN backward (error voltage A)	DI2
3	Reference potential	GND I
4	-	-
5	VCCI	+5V
6	Data line OUT forward (error voltage B)	/DO2
7	Data line IN backward (error voltage B)	/DI2
8	-	-
9	Reporting input	* RBST

design B

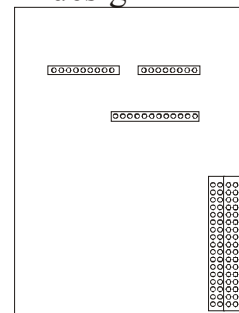

\* to forward Interbus-S interface

#### Remote IN

Remote IN (SUB D09 plug)  $\cong$  additional plug

Pin	Description	Designation
1	Datenleitung IN Hinweg (Differenzspannung A)	DO1
2	Datenleitung OUT Rückweg (Differenzspannung A)	DI1
3	Bezugspotential	GND I
4	-	-
5	-	-
6	Datenleitung IN Hinweg (Differenzspannung B)	/DO1
7	Datenleitung OUT Rückweg (Differenzspannung B)	/DI1
8	-	-
9	-	-

design B

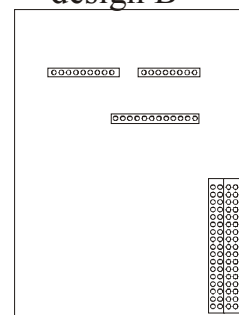

**Attention:** specific front panel is required !



## Digital interfaces

### 2.2.5.10 Pin assignment for I/O-Interface

with configuration board **RP EA5**, with galvanic separation

Digitale I/O option

**COM2** SUB D09 socket (I = input; O = output)

PIN	Designation	Comment	Status
1	BIAS input 101	standard	E
2	BIAS input 102	standard	E
3	BIAS input 107	standard	E
4	BIAS input 108	standard	E
5	0VSPS	ground reference 0VSPS	B
6	BIAS input 106	standard	E
7	BIAS output 109	standard	A
8	BIAS output 110	standard	A
9	+24VSPS	ext. +24V feed-in	UB

Bauform C

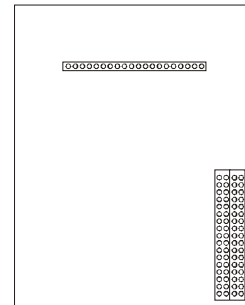

#### **Notice !**



The input's with the internal number 107 and 108 must be connected to the pin's with number 3 and 4.

The output's with the internal number 109 and 110 must be connected to the pin's with number 7 and 8.

### 3 Operating modes

The preselection of the device functions is carried out by choosing the operating modes 0...5 according to the following table, see chapter 3.1, (EASYRIDER .

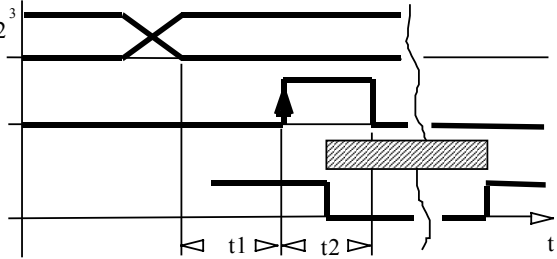
Each operating mode allows the assignment of different in- and output functions (F0..F5).

Operating mode	Reference-source	Hints for selecting the operating mode
<b>0, 1, 2</b>	analog (X10.5/18)	Replacement of devices series ESR AC S
<b>3</b>	analog (X10.5/18)	simple applications with requirement of switching between position and speed. control position controller handling like operating mode 4
<b>4</b>	digital or analog in acc. to parameter set	general position-controlled systems. Up to 10 positions can be stored under identifier-numbers and activated like shown.
	pos.selection (Nr 0..9) input start axis moves to selected positions-number. output position reached t1 = 3 ms min	function F2 daten 2 <sup>0</sup> ...2 <sup>3</sup> function F2 X10.2 function F0 X10.12 t2 = 3 ms min 
<b>5</b>	<b>digital or analog in acc. to programming or via digital communication (e.g. fieldbus)</b>	<b>simple to complex systems using instructions BIAS (up to 1500 command blocks)</b> <b>PLC - functions</b> <b>for further informations:</b> see chapter 13.1 EASYRIDER  and 13.2 BIAS-commands



### 3.1 Operating modes and pin functions

available pins number	Operating modes					
	<b>0</b> torque/ speed-control	<b>1</b> speed control	<b>2</b> torque control	<b>3</b> position/speed- control	<b>4</b> position control	<b>5</b> position control + BIAS functions
<b>Input X10.14</b>	F0, F1	F0, F1	F0, F1	F0, F1, F2, F3	F0, F1, F2, F3	<b>F0, F1, F2</b>
<b>Input X10.15</b>	F0, F1	F0, F1	F0, F1	F0, F1, F2, F3	F0, F1, F2, F3	<b>F0, F1, F2</b>
<b>Input X10.4</b>	---	---	---	---	F2	<b>F0, F2, F3</b>
<b>Input X10.25</b>	---	---	---	---	F2	<b>F0, F2, F3</b>
<b>Input X10.11</b>	---	---	---	---	F2	<b>F0, F2, F3</b>
<b>Input X10.24</b>	F0 L = torque- H = speed control	---	---	F0 L = position- H = speed control	F1, F2	<b>F1, F2, F3</b>
<b>Input X10.2</b>	---	---	---	---	F0	<b>F2, F3</b>

<b>Output X10.12</b>	F0	F0	F0, F2	F0, F1	F0, F1, F3	<b>F0, F1, F2, F3</b>
<b>Output X10.13</b>	F0	F0	F0, F2	F0, F1	F0, F1, F3	<b>F0, F1, F2, F3</b>
<b>Output X10.20</b>	F0	F0	F0, F2	F0, F1	F0, F1, F3	<b>F0, F1, F2, F3</b>
<b>Output X10.23</b>	F0	F0	F0, F2	F0, F1	F0, F1, F3	<b>F0, F1, F2, F3</b>

The assignment of the functions F0..F3 is listed in the following table



### 3.2 Configurable pin-functions (depending on the operating mode)

Input functions (depending on the operating modes)					
Input number	Function F0	Function F1	Function F2	Function F3	Example
<b>Input X10.14</b>	☒	limit switch +	*) set selection data 2 <sup>0</sup>	move manually +	limit switch +
<b>Input X10.15</b>	☒	limit switch -	*) set selection data 2 <sup>a</sup>	move manually -	limit switch -
<b>Input X10.4</b>	☒	latch input 1	*) set selection data 2 <sup>b</sup>	☒	set selection data 2 <sup>0</sup>
<b>Input X10.25</b>	☒	latch input 2	*) set selection data 2 <sup>c</sup>	☒	set selection data 2 <sup>1</sup>
<b>Input X10.11</b>	start (slope 0-->1) for BIAS -move commands	☒	*) set selection data 2 <sup>d</sup>	☒	set selection data 2 <sup>2</sup>
<b>Input X10.24</b>	operating mode selection	Referenzsensor	*) set selection data 2 <sup>max</sup>	☒	Referenzsensor
<b>Input X10.2</b>	start (slope 0-->1) with position set selection in position control	☒	strobe (slope 0-->1) for BIAS-set selection	☒	strobe (slope 0-->1) for BIAS-set selection

<b>Output X10.12</b>	position reached	reference output	☒	Tracking window exceeded	
<b>Output X10.13</b>	temperature monitoring	reference output	☒	Tracking window exceeded	
<b>Output X10.20</b>	warning	reference output	☒	Tracking window exceeded	
<b>Output X10.23</b>	active ok (motor brake)	reference output	☒	Tracking window exceeded	

☒ BIAS-function, free programmable (in operating mode 5)

\*) With every row (from the top to the bottom) in which the function F2 is assigned to an input, the binary value (2<sup>n</sup>) increases by 1. (see example)

**Operating mode 4: only permissible set number 0 - 9 !**

☒ fast input for optimal timing



### 3.3 Function diagrams from inputs and outputs

Fault signal / protection function	Protection mode switching off in acc. with EASYRIDER config.- menu	Protection mode limiting acc. with EASYRIDER config. menu
<p><b>I<sup>2</sup>t regulator protection</b></p> <p>output Warning(F0) X10.20</p> <p>output Ready X10.8</p> <p>Warning display</p> <p>fault signal display</p>	<p>Warning time approx. 3 sec.</p> <p>I-LIMIT</p>	<p>max. current</p> <p>rated current of regulator</p>
<p><b>I<sup>2</sup>t motor protection</b></p> <p>output Warning(F0) X10.20</p> <p>output Ready X10.8</p> <p>Warning display</p> <p>fault signal display</p>	<p>Warning time approx. 3 sec.</p> <p>I-LIMIT</p>	<p>max. current</p> <p>rated current of motor</p>
<p><b>NTC-output stage protection</b></p> <p>output Warning(F0) X10.20</p> <p>output Ready X10.8</p> <p>Warning display</p> <p>fault signal display</p> <p>assume motor temperature curve</p>	<p>95 °C</p> <p>Warning time approx. 6 sec.</p> <p>I-LIMIT</p> <p>Temp. V1 V2</p> <p>R_NTC1 R_PTC R_NTC2</p> <p>t1 t2 t</p>	<p>90 °C</p> <p>100 °C</p> <p>Temp. V1 V2</p> <p>R_NTC1 R_PTC R_NTC2</p> <p>t1 t2 t</p>
<p><b>NTC-motor protection</b></p> <p>output Temp.(F0) X10.13</p> <p>output Ready X10.8</p> <p>Warning display</p> <p>fault signal display</p>	<p>switch off with R_NTC2</p> <p>Warning time approx. 6 sec.</p> <p>I-LIMIT</p>	<p>decrease as of R_NTC1</p> <p>Warning time approx. 6 sec.</p> <p>current limiting</p>
<p><b>PTC-motor protection</b></p> <p>output Temp.(F0) X10.13</p> <p>output Ready X10.8</p> <p>Warning display</p> <p>fault signal display</p>	<p>switch off with R_PTC after warning time</p> <p>Warning time approx. 6 sec.</p> <p>I-LIMIT</p>	<div style="border: 1px solid black; padding: 5px; text-align: center;"> <p>no limiting function with PTC</p> </div>
<p><b>Function Passive -Delay (recommaded by use of motor brake)</b></p> <p>input ACTIVE-OK(F0) X10.22</p> <p>setpoint internally to zero</p> <p>output stage Active</p> <p>output AKTIVE -OK(F0) X10.23 (holding brake)</p> <p>Nsetpoint</p> <p>tv; reaction time for brake</p>		

## 4 Mechanical installation

### 4.1 Mounting

Eurotherm digital servo drives may be installed only in a vertical position to guarantee the best air circulation for the cooling ribs of the heat sink. Vertical installation above other drive racks or above other heat producing devices can lead to overheating. In addition the drives are to be operated exclusively in Eurotherm racks or the compact enclosure respectively.

### 4.2 Control cabinet - mounting

Installation should be carried out only in a control cabinet in which the inside must be free from dust, corrosive fumes, gases, and all liquids.

Make absolutely sure that the condensing of evaporating liquids including atmospheric moisture, is avoided. Should the digital servo drive be installed in a place where condensation is likely, a suitable anticondensation heater must be installed. The heater must be SWITCHED OFF during normal operation.

Automatic switch off is recommended.

Eurotherm-digital servo drives should not be installed in areas which have been classified as dangerous, if they have not been installed in an approved enclosure in accordance with regulations and checked.

Make sure, there is enough cooling and space !(see sketch)

- only horizontal !
- on the side  
no distance is required

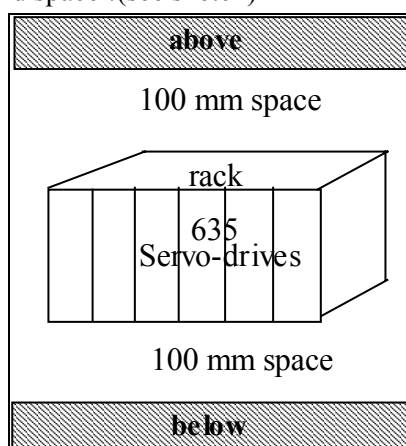

#### **General rule:**

It is better to place heat-producing devices low in an enclosure to support internal convection and to spread the heat. If placing such devices up high is unavoidable, enlarging the upper dimensions at the expense of height or installing fans should be considered.

### 4.3 Cooling

The digital servo drives are protected against damages caused by overheating.

There is a thermal sensor installed on the heat sink. When the temperature rises to  $>95^{\circ}\text{C}$ , the drive is automatically switched off. This setting cannot be changed.

Make sure a cabinet of proper size is selected for adequate air circulation.

**If the device becomes operated in a not ventilated device, the case volume of the specified control cabinet must be calculated in accordance with the following table !**

Device	Volume/control cabinet
635/K DER01...DER10	0,12 m <sup>3</sup>

**For more exact information, please, address to the control-cabinet manufacture**



## 5 Electrical installation

### 5.1 Safety

The voltages carried by power supply cables, motor cables, connectors, and certain parts of the drive can cause serious electric shocks and even death

### 5.2 The danger of electric shocks



#### CAUTION !

Risk of electrical shock, wait 3 minutes after switching off, for discharging the capacitors.

Disconnect Eurotherm plug-in units from mains before working on them. A period of **three** minutes **must** pass after switching off so that the internal capacitors can discharge completely. Until the discharge time is over, there can be dangerous voltages in the module !

Persons, which monitoring or carrying out electrical installation and maintenance must be adequately qualified and schooled in these activities.

### 5.3 Danger areas

The use of variable speed drives of all kinds can invalidate the certification for dangerous areas (apparatus group and/or temperature class) of explosion-protected motors. Inspection and certification for the complete installation of servo motors and electronic components **must** be obtained.

### 5.4 Grounding, safety grounding

The grounding impedance must meet the requirements of local industrial safety regulations and should be inspected and checked at appropriate and regular intervals

#### 5.4.1 Ground connections

It is recommended to attach a ground bus of high conductivity copper as near as possible to the servo-rack or regulator modules in order to minimize the length of the cable connections.

The recommended dimensions are:

**Thickness:  $d = 5$  to  $6$  mm**

Length (m)	Width (mm)	
< 0,5	20	
0,5 < 1,0	40	
1,0 < 1,5	50	

Ways of raised discharge currents > DC 10mA resp. > AC 3,5mA the PE-Bolt of the drive has to be connected to PE using copper-cable minimum 10mm<sup>2</sup> !

### 5.5 Short-circuit capability and discharge currents

Due to the working-principle of servo drives there may discharge currents to PE exceeding DC 10mA resp. AC 3,5mA.

Suitable for use on a circuit capable of delivery not more than 5000 RMS symmetrical amperes 505V maximum. (Note according to UL508C)

## 5.6 Fuses, contactors, filters

Compact Units			635/ K DER01.A3	635/ K DER03.A3	635/ K DER05.A3	635/ K DER07.A3	635/ K DER10.A3	
max. continous Input-Current		[Aeff] [A RMS]	4 (1-ph) 2 (3-ph)	6,5 (1-ph) 4 (3-ph)	11 (1-ph) 6,5 (3-ph)	14 (1-ph) 8 (3-ph)	10 (3-Ph)	
<b>Recommended Line-Fuses and Contactors</b>								
RCD-Switch			not recommendet. Required setpoint: 300 mA					
Mains protection	1)		T10A	T10A	T10A	T20A	T20A	
protector-switch	2)		PKZM0-16	PKZM0-16	PKZM0-16	PKZM0-16	PKZM0-16	
Mains contactor	2)		DIL 00M	DIL 00M	DIL 00M	DIL 00M	DIL 00M	
<b>Line Filters</b>								
general			only for use earth referenced supplies(TN). Current – drain to PE !					
<b>single-phase</b>								
industrial env. Max motorcable.50m (EN55011 A)	3)	model	LNF S 1*230/012 or LNF E 1*230/012					
residential env. Max motorcable.20m (EN55011 B)	3)	model	LNF S 1*230/012 oder LNF E 1*230/012					
<b>3-phase</b>								
industrial env. max motorcable.50m (EN55011 A)		model	LNF B 3*480/008					LNF K 3*480/018
residential env.. max motorcable.50m (EN55011 B)	3)	model	LNF B 3*480/008					LNF K 3*480/018
<b>3-phases, several servo-drives supplied by one common filter</b>								
industrial env. max motorcable.20m (EN55011 A)	4)	model	LNF B 3*480/018; LNF B 3*480/033 other models on request (according to ref.measurements with 3 units, supplied by common line)					
residential env. max motorcable.20m (EN55011 B)	3) 4)	model	LNF B 3*480/018; LNF K 3*480/033 other models on request (according to ref.measurements with 3 units, supplied by common line)					

- 1) recommended for UL-requirements: Bussmann Type FRS-R, 600V, use only UL-approved fuse-holders !
- 2) recommended, Klöckner Moeller for instance
- 3) Toroidal Ferrit, Eurotherm-model FR required at motor cable near to the drive.
- 4) Measurement of conducted emissions only.

Plug-in modules			635/ DER 01.A3	635/ DER 03.A3	635/ DER 05.A3	635/ DER 07.A3	635/ DER 10.A3
max. continous Input-Current	1-phase 3-phase	[Aeff] [A RMS]	4 2	6,5 4	11 6,5	1 8	10
<b>Fuses, Contactors, Filters</b>							
general			Orientation: Table for Compact-Units and the addition of rated currents of used units on the DC-Bus. Depending on the application, energy-sharing effects by DC-Link may reduce the required supply-current considerable				
Fuses			Rule of the Thumb: 1,5 to 2 times of added rated currents				
Power-On-Peaks			Depending on Power-Supply-Unit, Limiting equipment is required (Delay-Contactor)				
			only for use in earth referenced supplies(TN). Current-Drain to PE !				
Filter types			Orientation: Table of Compact-Units. Further Types: see separate manual				



## 5.7 Brake resistor

### 5.7.1 Selection of the brake resistor

The energy of a moving system flows back to the Drive. The DC-Bus capacitors are able to take a small value. The rest has to be converted to heat by a resistor.

Switching of this brake resistor depends on the DC-Bus voltage.

The load of the resistor is simulated and supervised electronically (EASYRIDER )

Peak power ( $P_{max}$ ) and continuous power ( $P_d$ ) ratings have to be sufficient to meet the requirements of the application.

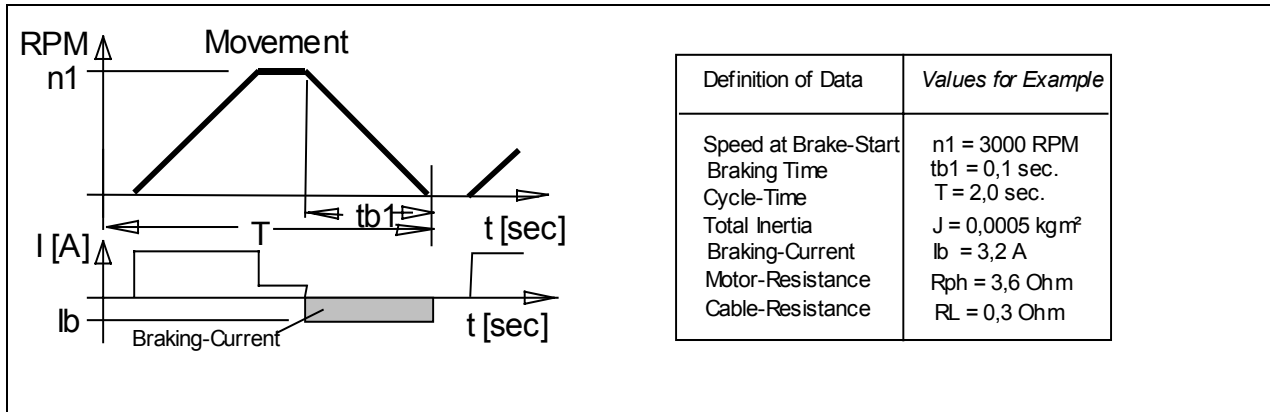

Calculation	
Step 1	example
<b>Calculation of brake-power</b> (Approximation. Capacitor-load, friction-and drive-losses neglected)	
Power of motion: $P_{kin} = 0,0055 * J * n1^2 / tb1$ [W]	$P_{kin} = 0,0055 * 0,0005 * 3000^2 / 0,1$ $P_{kin} = 247$ W
Motor-losses: $P_{vmot} = Ib^2 * (Ri + RL)$ [W]	$P_{vmot} = 3,2^2 * (3,6 + 0,3)$ $P_{vmot} = 40$ W
<b>Cont. Power:</b> $P_d = 0,9 * (P_{kin} - P_{vmot}) * tb1 / T$ [W]	$P_d = 0,9 * (247 - 40) * 0,1 / 2$ $P_d = 9,3$ W
<b>Peak-Power:</b> $P_{max} = (1,8 * P_{kin}) - P_{vmot}$ [W]	$P_{max} = (1,8 * 247) - 40$ $P_{max} = 405$ W
used units:	
J	total inertia [kgm <sup>2</sup> ]
n1	speed at Brake-Start [RPM]
tb1	braking time [Sec]
T	cykle time [Sec]
Ib	brake-current [A]
Rph	resistance of motor (between terminals) [ $\Omega$ ]
RL	line resistance of motor cable [ $\Omega$ ]

## Brake resistor

### Selection of the brake resistor

Step 2 Internal / external brake-resistor required ? see data in chapter 1.3.3 / 1.3.4	<b>Example-Drive model</b> <b>635/K DER03.A3</b>										
In case of insufficient capability or not included internal Brake-Resistor, a type may be selected from the following list.  External and internal Brake-Resistors will be switched in parallel. The internal and external performance-Data may be added in this case.	acc. to data in 1.3.3: internal resistor: Cont. Power Pd = 30W Peak Power Pmax = 1,4kW Required: Pd = 9,3W Pmax = 405W <b>Result: The internal capability is sufficient</b>										
external Brake-resistor	<table border="1"> <thead> <tr> <th>Ub-Stpoint</th> <th>Pp ext [W]</th> <th>Pd ext [W]</th> <th>Rb ext [Ohm]</th> <th>Eurotherm-Type</th> </tr> </thead> <tbody> <tr> <td>DC 376 V</td> <td>4260</td> <td>100</td> <td>33</td> <td>B100/33-3</td> </tr> </tbody> </table>	Ub-Stpoint	Pp ext [W]	Pd ext [W]	Rb ext [Ohm]	Eurotherm-Type	DC 376 V	4260	100	33	B100/33-3
Ub-Stpoint	Pp ext [W]	Pd ext [W]	Rb ext [Ohm]	Eurotherm-Type							
DC 376 V	4260	100	33	B100/33-3							

### 5.7.2 Configuration of the brake resistor

Possible ballast circuit configurations at digital devices

#### a) Compact design

The plug-in modules of servo-control series 635 / 637 are provided with an on board ballast electronics. It is intended for application as compact unit KDER resp. KD6R.

These compact units contain the necessary ballast resistor incl. fuse for the ballast circuit. Except KD6R 16..30-7 (external resistor only).

#### b) Rack design

While the plug-in modules are used in a rack, the NEB power supply module takes dissipation of the braking energy (adjustment of ballast monitoring: please see NEB manual).

In this case the ballast electronics of the plug-in module will be deactivated with the configuration parameter "Ballast aktiviert = N". All further ballast parameters are no longer relevant then.

#### r.g. a) Adjustment of ballast circuit for compact units:

In this case the ballast electronics of the plug-in module will be activated. "Ballast aktiviert = J". The operating point has to be adjusted dependent on the voltage variant.

"Ucc Ballast Ein = 375 V" for 230 V AC supply

"Ucc Ballast Ein = 720 V" for 400..460 V AC supply

As resistance value, the parallel resistance from internal and external resistance has to be adjusted.

e.g. "Ballastwiderstand = 300 Ohm" for KD6R-10 (internal resistance only)

"Ballastwiderstand = 75 Ohm" for KD6R-10 (+ external 100 Ohm / 100 W)

As ballast power (braking energy), the sum total of internal and external resistor power has to be adjusted.

e.g. "Ballastleistung = 30 Watt" for KD6R-10 (internal resistance only)

"Ballastleistung = 130 Watt" for KD6R-10 (+ external 100 Ohm / 100 W)

Precondition for correct monitoring of shunted ballast resistors is the nearly same ratio of P - cont. power to P - pulse power. This is guaranteed with the Eurotherm standard combinations.

KD6R 16..30-7 units do not contain an internal ballast resistor.

At these versions the values of the external resistor can be feeded directly.



## Brake resistor

### 5.7.3 Additional informations

Adjustment of load-supervision

used brake resistor R intern    R extern		EASYRIDER- data adjustment acc. to...
X		R intern
X	X	R extern
	X	R extern

#### **Paralleling of resistors:**

possible in respect of the limits in accordance to chapter 1.3.3 / 1.3.4

Genral rule for resistor data:

$$P_{\max} / P_d \leq 59$$



**Caution !**

#### **Placing of external brake resistors**

Brake-resistor are dissipating heat !

Make sure, that there will be no fire-danger in case of operating the resistor in nominal- or fail-conditions



## 6 Wiring instructions

### 6.1 General Information

Digital servo drives are designed for **operation in metallic grounded enclosures**. For perfect operation as well as for observance of all regulations the **front board must be connected with the enclosure electrically and fixed**.

### 6.2 Control cabling

Recommended cross section 0,25 mm<sup>2</sup>. The control signal lines must be laid separate from the power signal lines. (see chapter 6.7.1)

The resolver cable should contain three shielded pairs **and** be shielded as a whole. The shielding should be connected to the ground spread out on the regulator side. We recommend using Eurotherm resolver cable **KIR**. Cable for transmitting data are always to be laid shielded !

### 6.3 Power cabling

Recommended section according to rated current. Use only 75° Cu-cables.

### 6.4 Installation of the rack

When the rack is secured not in a hinged bay but on a mounting plate, it is recommended to do the wiring of the connections for the power connector X50 on the rear of the rack before installing. With hinged-bay installation, the customer must ensure that the parts sensitive to voltage such as the Ucc bus, mains supply lines, etc., are protected against electric shock.

### 6.5 Analog setpoint

The setpoint input is a differential input. Therefore the poling can be done depending on the requirements.

Important: the setpoint voltage must be galvanically connected to the reference potential of the control connections (plug X10). It is possible to connect one pole directly to GND.

### 6.6 Safety rules



**CAUTION !**

**Plug / unplug all modules only when**

**Ucc (DC-BUS) is off, that is, the green LED on the power supply module is off and the discharge time > 3 minutes has elapsed.**

**The user must ensure protection against accidental touching.**

### 6.7 Electromagnetic compatibility (EMC)

Conformity in accordance with the EEC Directive 89/336/EEC has been evaluated using a reference-system, consisting of a compact type drive and a line-filter on mounting-plate, connected to an AC-synchronous motor.

Mainly responsible for EMC-emissions is the motor cable. So this has to be installed exceptional carefully.





The layout of grounding is very important. Grounding has to be low-impedant for high frequencies. That means, all ground-connecting parts have to use area.

The measurements made are valid under the use of Eurotherm - cables, suppression aids and line filters and by application of the following wiring instructions:

## Wiring instructions

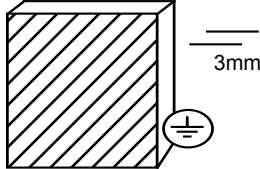
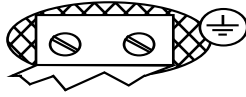
### Electromagnetic compatibility (EMC)

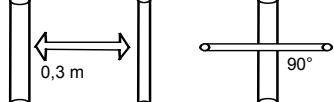
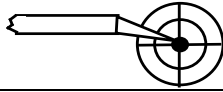
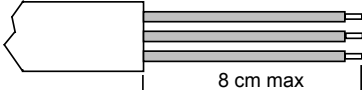
#### 6.7.1 Hints for mounting

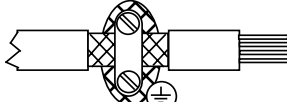
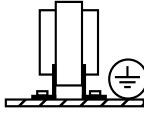
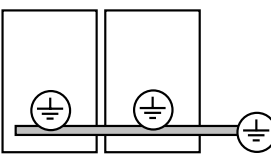
<b>A</b>	All components are mounted inside of a steel control cubicle on a mounting plate (thickness min. 3mm). Recommended: Galvanizing	
<b>B</b>	The connection between drive housing filter-housing and mountig-plate must be blank and not reduced by varnish. All screws must be well fixed !	
<b>C</b>	Use only Eurotherm-filters and cables for motor and resolver	
<b>D</b>	Place all wires and cables as close as possible to any grounded metal planes	
<b>E</b>	Separate power- and control cables. Minimum distance: 0,3m Crosspoints: 90°	
<b>F</b>	Avoid cable-loops. Especially the line between line-filter and drive has to be as close and short as possible (drilled)	
<b>G</b>	Maintain screen as close as possible to the cable-end (max distance 8 cm)	
<b>H</b>	Connect screen-connections according to general view of connetions, see chapter 2.1. Ground screens on both sides, shortest way. For long cables: Connect additional screen-area along the way	
<b>I</b>	Connect screens area-contacted to good grounded points	
<b>K</b>	Connect unused wires in cables to ground	
<b>L</b>	Install control cables directly close to grounded metal-parts or screend when leaving the control-cubicle	
<b>M</b>	Take care for good grounding of control-transformer (DC 24V). Use transformer with metal-socket and take care for conductive contact to mounting-plate	
<b>N</b>	Take care for good general grounding of the complete system. Interconnect several mounting-plates with copper-rails or copperband. Take care for ground connection between conrol-cubicle and machine !	

# Wiring instructions

## Electromagnetic compatibility (EMC)

### 6.7.2 Example for mounting

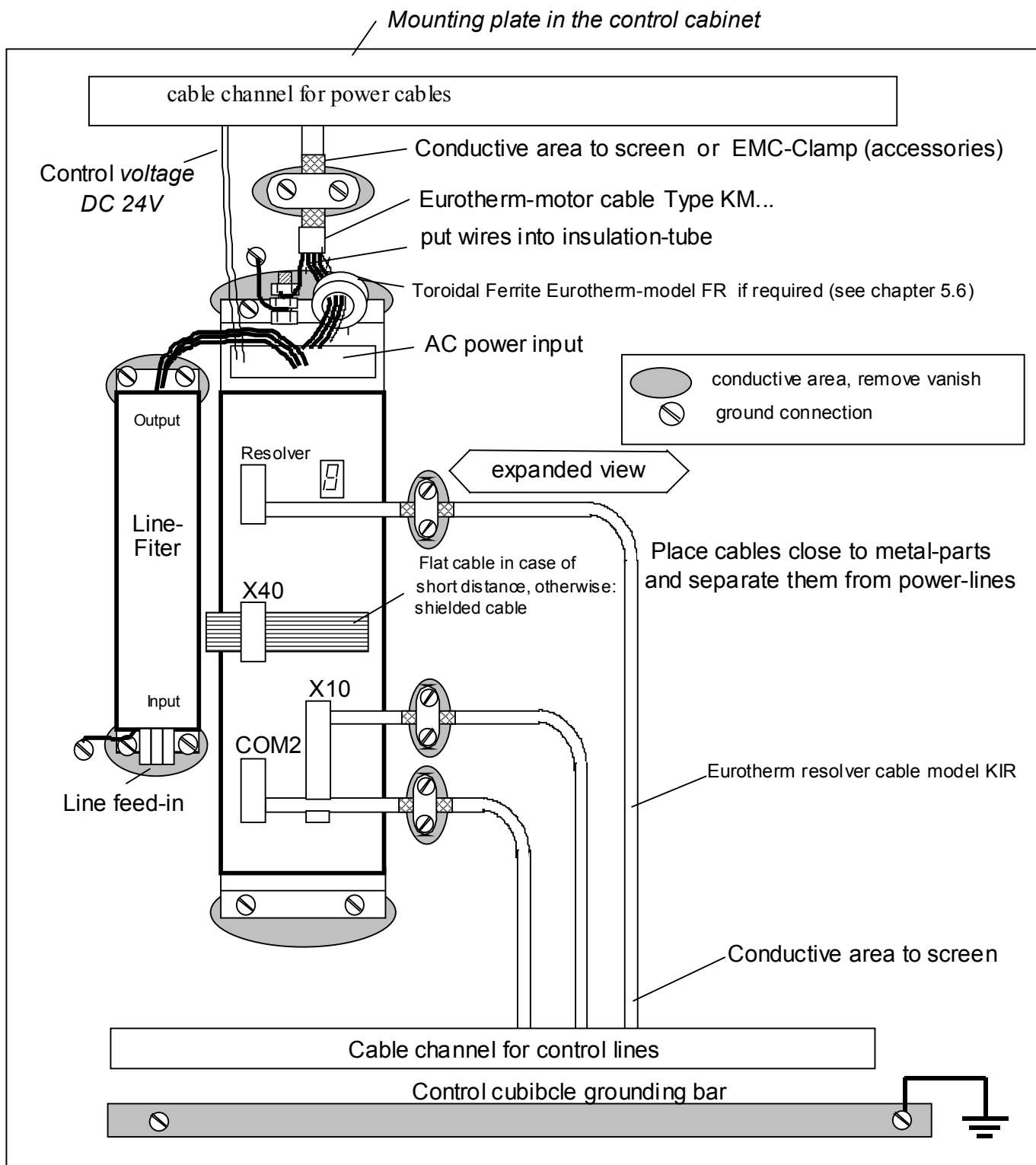



## Wiring instructions

### Electromagnetic compatibility (EMC)

#### 6.7.3 Achievable specifications and conditions

	Area	Class	Standard	conditions		additional conditions	
				Motor-cable length	Eurotherm line filters	mounting in	additional
Emissions: transmitted by cable or by air	Industrial	A	EN50081-2/ EN55011 Klasse A	see chapter 5.6	LNF S/E LNF B	closed cabinet with ≥ 15 dB attenuation	toroidal ferrite cores see chapter 5.6
	Residential	B	EN50081-1/ EN55011 Klasse B	see chapter 5.6	LNF S/E LNF B		
Interference immunity: (≅ radiation) transmitted by cable or by air	Industrial	A	EN50082-2	-	-	-	-
	Residential	B		-	-	-	-

## 7 Setting and programming

### 7.1 Jumper

**All jumpers are set to a standard position in production !**

To setup configuration in case of replacement of units series ESR the following solder jumpers can be adjusted. (see chapter 1.4.3)

<b>JP100, bridged pad...</b>	
2 and 3 (standard)	READY contact with reference to common output supply voltage on X10.21
1 and 3	READY contact can be wired freely

<b>JP101, bridged pad...</b>	
2 and 3 (standard)	Analog input X10.19 without internal Pull-up.
1 and 3	Analog input X10.19 with internal Pull-up to +12 V (ESR compatible)

<b>JP102, bridged pad...</b>	
2 and 3 (standard)	X10.23 = active ok. output
1 and 3	X10.23 = GND internal (ESR compatible)

### 7.2 Digital communication

see chapter 1.1.1

### 7.3 PROG-key functions

#### 7.3.1 Description for PROG-key

Simple changes of the parameters can be made without any further aids directly on the device as follows:

#### Conditions for activating:

- PROG-key function is allowed. (EASYRIDER )
- Local mode selected no HOST LOGIN
- only possible in interference-free state

#### Activating the programming operation:

PROG-key approx. 4 seconds to the left

#### Characteristic of the programming operation:

blinking display alternately:  
mode-identifier / value

#### Change values:

press key left or right according to the following tabel

The whole range is divided in 32 steps and will be displayed as follows:

**smallest value**                      **largest value**

*101, 101, 111, 111, ..... 1F1, 1F1*

If an error occurs, the programming operation is switched off.



## PROG-key functions

### 7.3.2 Operating via PROG-key

PROG-key	Remark	Function	Value range	Display	Remark
		<b>normal operation</b> <sup>1)</sup>		-. or .	
	hold for 4sec.				
		reserved		E	flashes
	hold for 4sec.				
		<b>maximal current limit</b>	0 ... F	n	alternates blinking
	press briefly	set	0 ... F	n	
	hold for 4sec.				
		<b>speed-0 adjustment</b>	Keiner	0	flashes
	press briefly	adjustment: a) ok b) not possible		a)  H  b)  E	flashes
	hold for 4sec.				
		<b>P-gain-setting of the speed controller</b>	0 ... F	P	alternates blinking
	press briefly	set	0 ... F	P	
	hold for 4sec.				
		<b>I-gain setting of the speed controller</b>	0 ... F	J	alternates blinking
	press briefly	set	0 ... F	J	
	hold for 4sec.				
		<b>Setpoint evaluation:</b>	0	H	alternates blinking
	press briefly	set: -5,+5 rpm/step	F , I	H	
	hold for 4sec.				
		<b>Axis number designation:</b>	0 ... F	H	alternates blinking
	press briefly	set:  0  Nr./no. 1  F  Nr./no.32	0 ... F	H	
	hold for 4sec.				
		<b>Store in EPROM?</b>	-	E	flashes
	hold for 4sec.	yes	-	.	norm. operation <sup>1)</sup>
	hold for 4sec.				
		=> <b>normal operation</b> <sup>1)</sup>	-	.	

1) normal operation: Ucc and Us on, no failure



## 8 Commissioning



### CAUTION !

**Wiring errors or incompatible operation may cause unpredictable motions.  
Avoid danger for men and machine !**



### 8.1 Preparation

- For PC-link use the Eurotherm communication software EASYRIDER . For the start, we suggest exercises in simulation mode to get familiar with EASYRIDER. This chapter presumes the knowledge how to handle EASYRIDER. Suggestions: Use testequipment to train yourself. EASYRIDER  contains interactive HELP - functions.
- For security-reasons the access to several functions is blocked by password. Commissioning has to be executed by trained stuff only.
- Users may have their application-adapted commissioning methode when familiar with the product, on their own responsibility.
- The system must be in accordance with all valid safety specifications. The function of all safety equipment (limit-switches for example) have to be checked.
- To activate the power-stage of the drive, the "ACTIVE"-signal (X10.22 against X10.9) has to be exited.



## Commissioning

### 8.2 Commissioning in steps

Step	Action	Remark
1	<b>Before switching on</b> Check the wiring, especially: Filterpolarity, supply motor wiring, motor polarity resolver wiring, polarity (or other feedback systems)	
2	with critical mechanical parts: remove motor shaft from application	avoid danger
3	Connect PC by RS232 link to the drive service port COM1 and start EASYRIDER	
4	<b>Set up state</b> <b>NOT ACTIVE (X10.22 against X10.9)</b> <b>Power ON</b>	7-Segment-display 
5	Switch on control voltage Us (DC 24V) EASYRIDER communicates (see diagnosis F9)	7-Segment-display 
6	Are parameters already evaluated ? <b>yes:</b> load parameter file xxx.ASD. Store parameters in the drive. If existent: load BIAS-file xxx.EEUROTHERM and store it in the drive. proceed with <b>10 or 15</b> (experts)	<b>no:</b> continue with 7
7	Menue Comissioning: Select the used motor from the EASYRIDER- Library Adjust max. current to nominal motor current or smaller	reduced torque
8	When leaving that menue: Tuning-parameters for current loop will be calculated and offered to the user. Normally, these values give dynamic servo motion.	confirm acceptance of offered parameters
9	store data power-fail-save in the drive (F7)	
10	<b>Menue: Tuning speed loop</b>	



# Commissioning

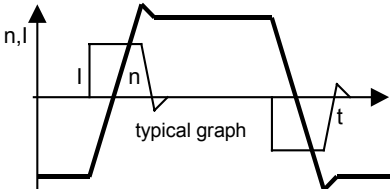
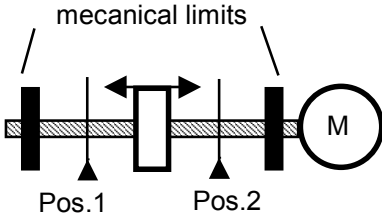

## Commissioning in steps

Step	Action	Remark
11	"ACTIVE" switched	7-Segment-display 
12	Adjust test generator as required. Activate test generator with "START Motor". Activate graph to display motor current or speed. can be optimized manually (P- and I-gain)	
13	Is the result ok? <b>yes:</b> continue with 14   <b>no:</b> continue with U1	
14	Preparation to the position controller The commissioning of the position controller is first recommended without linked up mechanics. In the case of secure functions, the mechanics can then be linked up.	
15	<b>Power OFF.</b> connect motor-shaft to the application Move application to a free area between mechanical limits. <b>Power ON</b> <b>Menu: Tuning position loop</b>	
16	Adjust testgenerator. Select Pos.1 and Pos .2 to uncritical values. Select slow speed and slow acceleration first, rise up later.	mind: reaction-time to <b>Emergency Stop</b>
17	"ACTIVE" - switched. Every activation of "START Motor" exits a motion from Pos. 1 to Pos.2 and, with the next activation, from Pos 2 to Pos. 1	
18	Observe the behavior of application and graph. Optimize tuning-parameters (P-, I- andV gain)	
19	Is the result ok? <b>yes:</b> continue with 20   <b>no:</b> continue with 9	
20	<b>Basic power-up is done now.</b> Further functions (Interfaces, fieldbus functions, synchronizing and so on may be done adapted to the selected equipment.	
21	Select the menu <b>File</b> "store parameters" and store the data in the regulator, protected against loss, with the F7-key.	data save

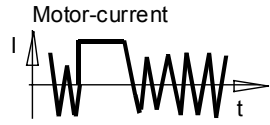

# Commissioning

## Commissioning in steps

Step	Action	Remark
<b>U1.1</b>	<p><b>Menu: Tuning Speed Loop</b>            Stable parameters are calculated bases on the system data; and can be called up with F5.            Sometimes it is recomanded to make further manual tuning.            Rated values can be sourced either digital by the internal generator or analog by using +/-10V at X10.5/18.</p> <p><b>ATTENTION !</b>            Too hard tuning will cause current-ripple and high power-dissipation.</p>	 <p>P-Gain too high or I-time constant too small Motor-noise</p>
<b>U1.2</b>	<p>Too weak adjustment causes slow loop-reactions, that may cause problems for the tuning of position loops.</p>	 <p>P-Gain too small I or I-time constant too high</p>
<b>U1.3</b>	<p>Is the result ok?  <b>yes:</b> continue with <b>9</b>   <b>no:</b> continue with <b>U2.1</b></p>	
<b>U2.1</b>	<p><b>Menu: Tuning Current Loop</b>            Stable parameters are calculated bases on the system data and can be called up with F5.            Manual tuning may be sensfull.            Rated values can be sourced either digital by the internal generator or analog by using +/-10V at X10.5/18.</p> <p><b>ATTENTION !</b>            Tuning of current loop should be only done after consultation of Eurotherm experts.  <b>continue with 9</b></p>	

## 9 Diagnosis and trouble shooting

### 9.1 7-Segment-display

Many sources of faults can be narrowed down with the diagnosis display.

Display	Explanation	output Ready	output <sup>2)</sup> Warning	Comment
.	drive ready for operation !			DC-bus within the boundaries regulator ready not activ
/	no display	off	off	any control voltage? external fuses ok?
-	system ready for operate	on	off	regulator ready not activ
-	drive active BIAS-program stop	on	off	The drive is activated during the delay time for brake in operating mode position control. (The BIAS-proram does not start). <b>from Firmware 6.11b</b>
-	internal STOP with serial deactivating	off	off	activate drive via serial interface
-	regulator of serial interface (bus interface) deactivated !	off	off	only if bus interface is integrated
-	Activ input is activated with switching on	off	off	switch enable X10.22 low and then high
U	DC bus undervoltage <Ua low threshold	off	off	power supply switched on? power supply unit ok? internal fuses ok? Error signal disappears, if DC-bus voltage over the threshold.
/	undervoltage in DC-bus	off	off	Check power supply undervoltage parameter check
E	fault in resolver system	off	off	wiring to encoder system ok? encoder system ok? encoder system supply ok?
E	I <sup>2</sup> t-overload of the drive	<sup>1)</sup>	<sup>1)</sup>	does the control loop oscillate? P-amplification too high mechanics stiff? requirements too high? is warning /8/ evaluated?
U	overload of the motor I <sup>2</sup> t	<sup>1)</sup>	<sup>1)</sup>	does the control loop oscillate? P-amplification too high mechanics stiff? requirements too high? is warning /8/ evaluated?

<sup>1)</sup> Reaction to these errors see chapter 3.3

<sup>2)</sup> With configuration corresponding chapter 3.1



## Diagnosis and trouble shooting

### 7-segment display

Display	Explanation	output Ready	output <sup>2)</sup> Warning	Comment
/5/	overtemperature of the output stage (> 95°C)	1)	1)	adequate cooling of the drive? ambient temperature too high?
/6/	overvoltage on DC bus	1)	1)	ballast module ok? adequate ballast module?
/7/	chassis shorting and short circuit due to hardware	off	off	motor cabling ok? digital-loops setup ok? short circuit to chassis in the motor? braking resistor: ohm- value too low? try to start fresh! send in for repair
* /8/	WARNING! overload of the regulator I <sup>2</sup> t or motor I <sup>2</sup> t or temp.-output stage too high. If no reaction within approx. 3sec.it switches off with signals /3/, /4/ or /5/. Signal /8/ clears when there is no more danger or it is switched off	on	1)	mechanics stiff? defective bearings; cold grease? reduce requirements and creep to next possible STOP
/9/	overtemperature motor (NTC/PTC)	off		check overload of the motor / cooling etc.
* /h/	motor tempera- ture too high	on	1)	check overload of the motor / cooling etc.
/-/	ballast active			Brake vigour is removed
/u/	warning I <sup>2</sup> t ballast too high	on	1)	ballast resistance usage >90%
/U/	switch off ballast	on	1)	ballast resistance overloaded
* /l/	tracking window exceeded			only in operation mode position control, will be deleted with the next run-command
/L/	tracking error with switch off			only in operation mode "position control"
/y/	Memory-Checksum-Error	off	off	try new start

<sup>1)</sup> Reaction to these errors see chapter 3.3

<sup>2)</sup> With configuration corresponding chapter 3.1

\* Only warning respect. status indicator

The error signals are shown as long as there is control voltage (Us), also when the power (DC-Bus) is switched off for safety reasons.

## Diagnosis and trouble shooting

### 9.2 Reset of a regulator trouble

The error signals 2 - 7, 9,  $\epsilon$ , U, u, Y of the drive can be reset via

1. Control voltage OFF/ON,
2. the programming switch,
3. the serial command "Drive Reset" 0x02

or

4. the fieldbus-command " Drive Reset" 0x16 (22 decimal)

A general precondition for correct execution of the Reset is the elimination of the error cause

**Further preconditions are:**

**for RESET with the programming switch**

- a. The active input X10.22 must be deactivated.
- b. No host registration have to be occurred.
- c. The programming switch function must be activated.
- c. Hold the programming switch for 1sec. on the right side.

**for RESET with the serial command "reset drive" 0x02**

The host registration must be occurred.

The drive must be deactivated via the serial command "deactivate Drive" 0x00.

**for RESET with the BUS command "reset drive" 0x16**

The host registration must be occurred via the BUS command 0x01.

The drive must be deactivated via the BUS command "deactivate Drive" 0x14.

The fieldbus command "Drive Reset" with constant repetition of the fieldbus command 0x16 will be works-off only once.

For further processing, it is necessary, meanwhile to send another control word (e.g. 0 status order).

**Notice !!**

After remove of the tracking error deactivation " $\epsilon$ ", the warning message "L" (tracking error) is active up to the next move command.

The error signal " $\equiv$ " (releasing before ready) can be reset by deactivation the drive



## Diagnosis and trouble shooting

### 9.3 Trouble shooting

The following list refers to faults which can occur during operation.

Display: /./ •/

Error	Explanation and remedy	
no motor run despite current flow	motor mechanically blocked? motor brake released?	1)
motor runs unevenly	check setpoint wiring check grounding and shielding too high P-amplification in the speed controller reduce value (with EASYRIDER setting/speed controller or PROG-key) too small I-time in the speed controller? reduce value (with EASYRIDER setting/speed controller or PROG-key)	
no reaction of setpoint progression, despite torque in standstill	Limit switch functions effective (BIAS)	
no current flow; no torque despite activating the regulator correctly	motor cables interrupted? Is input "I extern" (X10.19) activated (config. menu) and not notched up? Are the inputs Enable N- and Enable N+ (config menu) activated and not notched up?	
Interference symptoms with power frequency	Ground loops in setpoint or actual value wiring? Shieldings laid on both sides? Signal cables near high voltage cables?	
Motor takes up preferred positions after activation	Position encoder or motor cables with reversed poles? Resolver or encoder incorrectly adjusted? Number of motor poles wrong matching? (config. menu)	1)
Motor runs up immediately after activation although there is no setpoint	Motor cables or resolver cables reversed? Resolver incorrectly adjusted?	1)
Motor reaches in idling cycle very different speed when running to the right or to the left	Resolver incorrectly adjusted	

1) Display /3./ or /4./ mostly short after activating; before warning /8./

# 10 Block circuit diagram

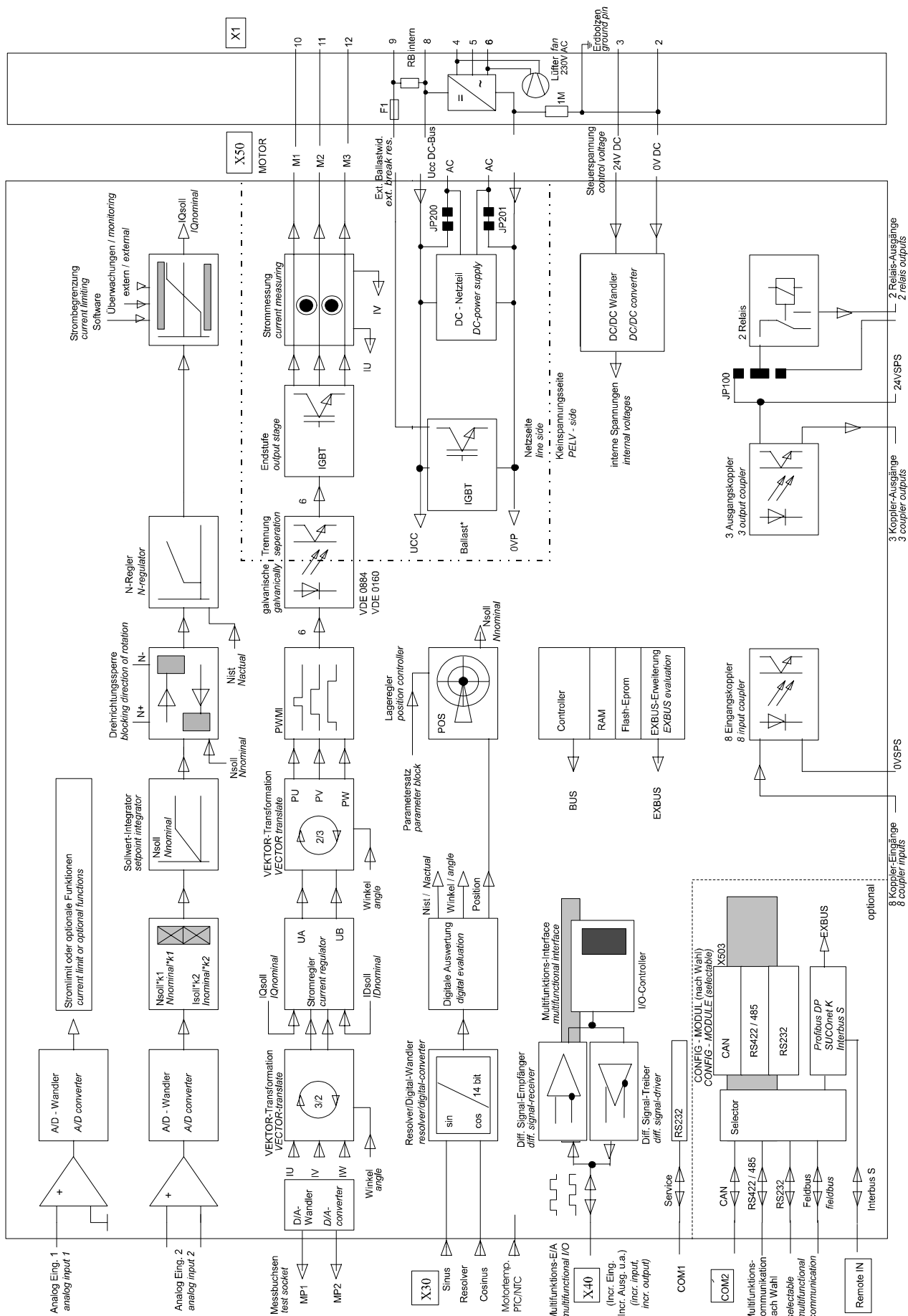



## 11 General technical data

### 11.1 Power circuit

galvanic separation from control circuit	in acc. with VDE 0160
specification in accordance with	UL 508C and cUL
short circuit and to frame proof for	£ 2000 releasings
overvoltage monitoring	max. 400V DC ±5V DC
undervoltage monitoring	min. 15V DC; configurable
overtemperature switch off at	95 ° C +/- 5%
clock frequency	9,5 kHz
frequency of current ripple	19 kHz
Form factor of output current	1,02

### 11.2 Control circuit

galvanic separation from power circuit	in acc. with VDE 0160
further informations:	see concept of insulation chapter 1.3.1
	see data compact units chapter. 1.3.3
	see data plug-in modules chapter 1.3.4

### 11.3 Signal inputs and outputs, connection X10

additional galvanic separation from power and control circuit	
nominal voltage of the in- and outputs	24 V DC
number of outputs signal outputs via OPTO coupler	5 $U_{\max} = 45V DC$ ; $I = 0..60 mA$ ; short circuit proof, resistive load
signal outputs via RELAY	$U_{\max} = 45V DC$ ; $I = 1uA...1,2A$
contact protection with inductive load	internal varistor
number of inputs signal outputs via OPTO coupler	8 $L = 0...7 V DC$ or open $H = 15...30 V DC$ $I_{in} 24VDC @ 8 mA$
reaction time of the inputs X10.2, X10.4, X10.11, X10.14, X10.15, X10.24	> 2 ms
reaction time of the inputs X10.4, X10.25 (configured as latch input "see chapter 3")	0,2 ms
Effect of cycle-time	≤ 0,02 ms



## General technical data

### 11.4 Digital control

a) current control	
settings	according to factory specifications or motor data
current limits	speed control menu or PROG-key
externally through fixed voltage	0..10V = 0..100%; can be normed
resolution	10 bit
b) speed control	
settings	speed control menu or PROG key
differential setpoint input analog	$U_{soll} = 10 \text{ V}$ , can be normed; $R_i = 10k$
resolution (including sign)	12 bit
digital setpoint input	via interfaces
c) position control	

### 11.5 Digital communication

RS232 - service interface	COM1
<u>optional</u> RS232 / RS 422 / RS 485 on SUB D - socket CAN, Profibus DP, SUCOnet K on SUB D - socket Interbus S on SUB D - socket (OUT) Interbus S (Remote IN)	COM2      additional SUB D plug
standard-protocol	19200 baud, 8 databits, 1 startbit, 1 stopbit, parity: even

### 11.6 Resolver evaluation / transmitter principle

<u>General:</u> The specified data refer to the combination of the standard resolver interface; operated with the Eurotherm resolver R 21-T05, R15-T05	
carrier frequency	$f_t = 5 \text{ kHz}$
linearity error of the actual value signal	1%
ripple of the actual value signal	2%
max. position resolution for one revolution	16384 Incr. 14 bit
absolute position accuracy	+/- 0,52 °
relative position accuracy	+/- 0.08 °



## General technical data

### 11.7 Controllsystem

system run-up time after switching on the control voltage	max. 6 sec.
data memory / organization	Flash Eprom 256 KB RAM 64 KB; EEPROM 256 Byte

### 11.8 Measuring sockets MP1 and MP2

signal range	-10V.....0.....+10V magnifier function can be normed
resolution	7 bit, independend of norming
internal resistance	10 k

### 11.9 Thermal data

Thermal data	see chapter 1.3
--------------	-----------------

### 11.10 Mechanical data

dimensions	see chapter 1.4
weight	see chapter 1.3

**Further data you will find in chapter 1.3.3**

## 12 Disposal

The digital servo drive consists of different materials.

The following table shows, which materials can be recycled and which have to be disposed of in a special way.

<b>material</b>	<b>recycle</b>	<b>disposal</b>
metal	yes	no
plastics material	yes	no
printed board assembly	no	yes

**Dispose of the appropriate materials in accordance with the valid environmental control laws.**



## 13 Software

### 13.1 EASYRIDER

EASYRIDER  is a comfortable tool to use all drive functions. Detailed Online-Help-information and instructions are available.

EASYRIDER Instructions: (extract)

- Autopilot-function as interactive tutorial
  
- System identification
- BIAS - instruction-set editor
- Oscilloscope-function
- start-up and commissioning-tools
- Setting of parameters
- Setting of configurations
- Servo-diagnostics
- Interface diagnostics
- Fieldbus diagnostics
- Motor library
- save system data in file
- load system data from file
- send system data to servodrive
- save system data in servodrive
- load system data from servodrive

#### **Important:**

Edited data in EASYRIDER are transmitted to the RAM of the servodrive and **active after** use of the instruction **SEND**. **Only the instruction SAVE in EEPROM** writes data into a nonvolatile memory. Data are stored there power-fail save.

## Software

### 13.2 BIAS- commands

In **operating mode 5** - position control with BIAS, two user-defined programs can be processed parallel. The BIAS program (incremental) for the one and the PLC-program (cyclic processing) for the other. Whereas the BIAS program is processed as of startblock immediately after activating operating mode 5. The PLC-program is first started with the BIAS command, "PLC-program".

with the Eurotherm programming language

**"BIAS"**

User shell for intelligent drive controls

The following command groups exist within the set parameters:

Organisation commands

- Fixing start and end of the main-programs and subroutines
- Conditional and unconditional jump commands

Commands relevant to motion

Set/delete commands for outputs and flags

Commands for variables

The user has the possibility to program his sequence himself from this set of commands.

Available program area	
Set number	
0000 -	
...	
...	can be selected via
...	data inputs X10.xx
...	max. to block no. 63 and
...	and Strobe X10.2
...	
0063 -	
1499 last block	

The BIAS operation set is listed on the next page.

You can read the exact function of the individual commands in the help function of the EASYRIDER software in the BIAS editor or in the BIAS command description (UL:10.6.5).

## BIAS - commands

	0	1	2	3	4	5	6	7	8
0	move position	move position + parameter	position =	position = [variable X]	[variable X] = position	NOP	flag X =	If input X ?	[variable X] =
1	move incremental position	move incremental position + parameter	speed =	speed = [variable X]	[variable X] = speed	end of program	If flag X = ?	If output X ?	If [variable X] ? const.
2	move datum	move datum + parameter	acceleration =	acceleration = [variable X]	[variable X] = acceleration	sub-program	flag X = flag Y	output X =	[variable X] = [variable Y] + const.
3	move infinite positive	move infinite positive + parameter	deceleration =	deceleration = [variable X]	[variable X] = deceleration	end of sub-program	flag X = input Y	output X = flag Y	[variable X] = [variable Y] - const.
4	move infinite negative	move infinite negative + parameter	gear factor =	gear factor = [variable X]	[variable X] = gear factor	PLC-program	flag X = output Y		[variable X] = [variable Y] * const.
5	move synchron	move synchron + parameter	"position reached" window =	"position reached" window = [variable X]	[variable X] = block-number	jump	flag X = flag Y & flag Z		[variable X] = [variable Y] / const.
6	move cam-profile	move analogue value + integrator	remaining position =	remaining position = [variable X]	[variable X] = actual position Y	jump [variable X]	flag X = flag Y   flag Z		[variable X] = flag Y, number Z
7	synchronous settings 1	move speed + integrator	ramp filter =	maximal current = [variable X]	[variable X] = analogue input Y	BIAS execution pointer	flag X = flag Y ^ flag Z		
8	synchronous settings 2		actual position X =	actual position X = [variable Y]	[variable X] = latchposition Y	wait for "position reached"	flag X = !flag Y	IBT-masknumber =	[variable X] = [variable Y]
9	move PID ; speed		If actual position X ? const.	analogue output = [variable X] (*)	[variable X] = actual speed Y	wait time	flag X = status Y	IBT-notification number =	If [variable X] ? [variable Y]
A	move PID ; torque	cycle length =	If actual position X ? [var.Y]	PID scaling	[variable X] = latchstatus Y	wait time [variable X]	If status X ?	CAN-command = [variable X]	[variable X] = [var. Y] + [var. Z]
B		cycle length = [variable X]	sensor window	sensor window = [variable X]	[variable X] = position Y	BIAS execution pointer = [var. X]	mode X =		[variable X] = [var. Y] - [var. Z]
C			sensor position	sensor position = [variable X]	[variable X] = value Y		flag X = [variable Y], number Z		[variable X] = [var. Y] * [var. Z]
D			sensor adjustment 1	sensor adjustment 1 = [variable X]					[variable X] = [var. Y] / [variable Z]
E	start axis		sensor adjustment 2	sensor adjustment 2 = [variable X]					[teachvar. X] = [variable Y]
F	stop axis	stop axis + parameter	update parameter	PID parameter		virtual program			[variable X] = [teachvar. Y]

start axis only defined in BIAS-program

stop axis defined in BIAS- and PLC-program

BIAS-execution pointer defined in PLC- and Math.-program

flag X = defined in BIAS-, PLC- and Math.-program

### 13.3 BIAS- extended command overview

	9	10	11
0	Mathematics-program	table[Variable X] =	[ D_Variable X] = [ D_Variable Y] + [ D_Variable Z]
1	Profil-initialization	table[Variable X] = [ y Variable Z]	[ D_Variable X] = [D_Variable Y] - [D_Variable Z]
2	Profil-cycle length	[ x_Variable Y] = table[Variable Z]	[D_Variable X] = [D_Variable Y] * [D_Variable Z]
3		[ w_Variable X] = [ y_Variable Z]	[D_Variable X] = [D_Variable Y] / [D_Variable Z]
4		[ x_Variable Y] = const.	Wenn [D_Variable X] ? [D_Variable Y]
5			[D_Variable X] = SIN [D_Variable Y]
6			[D_Variable X] = COS [D_Variable Y]
7			[D_Variable X] = SQRT [D_Variable Y]
8			
9			
A			
B			
C			
D			
E			
F			

Mathematics-program defined in BIAS and PLC-program

Tabelle [Variable X] = only defined mathematics-program

**from EASYRIDER and Firmware Version V5.10 !**





# VDE Prüf- und Zertifizierungsinstitut

## ZEICHENGENEHMIGUNG MARKS LICENCE

**Eurotherm Antriebstechnik GmbH  
Im Sand 14  
76669 Bad Schönborn-Langenbrücken**

ist berechtigt, für ihr Produkt /  
*is authorized to use for their product*

**Geräte, sonstige  
Other appliances**

die hier abgebildeten markenrechtlich geschützten Prüfzeichen für die  
ab Blatt 2 aufgeführten Typen zu benutzen /  
*the legally protected Certification Marks as shown below for the types referred to on page 2 ff.*



Geprüft und zertifiziert nach /  
*Tested and certified according to*

**DIN EN 50178 (VDE 0160):1998-04 EN 50178:1997**

Aktenzeichen: 19235-3990-0002 / F17 / EN

*File ref.:*

Ausweis-Nr.: 103310

*Licence No.:*

Weitere Bedingungen siehe Rückseite und Folgeblätter /  
*further conditions see overleaf and following pages*

Offenbach, 1997-08-18

(letzte Änderung/updated 1999-03-22)

Blatt 1  
page

VDE Prüf- und Zertifizierungsinstitut  
*VDE Testing and Certification Institute*  
Zertifizierungsstelle  
*Certification*







## Certificates

# VDE Prüf- und Zertifizierungsinstitut Zeichengenehmigung

Ausweis-Nr. /  
Licence No.  
103310

Blatt /  
page  
2

Name und Sitz des Zeichengenehmigungs-Inhabers / Name and registered seat of the Marks Licence holder

Eurotherm Antriebstechnik GmbH, Im Sand 14  
76669 Bad Schönborn-Langenbrücken

Aktenzeichen / File ref.

19235-3990-0002 / F17 / EN

letzte Änderung / updated

1999-03-22

Datum / Date

1997-08-18

Dieses Blatt gilt nur in Verbindung mit Blatt 1 des Zeichengenehmigungsausweises Nr. 103310.  
*This supplement is only valid in conjunction with page 1 of the Marks Licence No. 103310.*

Jahresgebühren-Einheiten /  
Annual fee units

**Geräte, sonstige  
Other appliances**

25,00

Typ(en) / Type(s):

**635/K DER 03  
635/K DER 05  
635/K DER 07  
635/K DER 10**

1,00  
1,00  
1,00  
1,00

Nennspannung 1/3/PE AC 230 V

Nennstrom: siehe Anlage Nr. 1

zulässige Umgebungstemperatur 0...40°C

Ausgangsspannungen und -ströme: siehe Anlage Nr. 1

Schutzmaßnahme Schutzklasse I

Schutzart Einbaugerät, die Servoregler sind ausschließlich zur Speisung von Eurotherm (oder von Eurotherm freigegeben) Servomotoren bestimmt.

Überspannungskategorie III

Kurzschlußfestigkeit bedingt kurzschlußfest

Transformator	Fa. J. Lasslop, Typ TIV2DER	2,00
	Fa. LEM, Typ LA-25-NP	2,00
	Fa. TELCOM, Typ HTP25NP	2,00
	Fa. Pulse FEE, Typ MTA 12358	
	Az.: 19235-3990-0003	

Fortsetzung siehe Blatt 3 /  
*continued on page 3*

VDE Testing and Certification Institute \* Institut VDE d'Essais et de Certification



Merianstraße 28, D-63069 Offenbach

Telefon (+49) (69) 8306-0  
Telefax (+49) (69) 8306-555



# Certificates

## VDE Prüf- und Zertifizierungsinstitut Zeichengenehmigung

Ausweis-Nr. /  
Licence No.  
103310

Blatt /  
page  
3

Name und Sitz des Zeichengenehmigungs-Inhabers / Name and registered seat of the Marks Licence holder

Eurotherm Antriebstechnik GmbH, Im Sand 14  
76669 Bad Schönborn-Langenbrücken

Aktenzeichen / File ref.

19235-3990-0002 / F17 / EN

letzte Änderung / updated

1999-03-22

Datum / Date

1997-08-18

Dieses Blatt gilt nur in Verbindung mit Blatt 1 des Zeichengenehmigungsausweises Nr. 103310.  
*This supplement is only valid in conjunction with page 1 of the Marks Licence No. 103310.*

Jahresgebühren-Einheiten /  
Annual fee units

**Summe der Jahresgebühren-Einheiten**  
*Sum of annual fee units*

**35,00**

=====

VDE Prüf- und Zertifizierungsinstitut  
VDE Testing and Certification Institute  
Fachgebiet F17  
Section F17

i. A. 

i. A. 

VDE Testing and Certification Institute \* Institut VDE d'Essais et de Certification



Merianstraße 28, D-63089 Offenbach

Telefon (+49) (69) 8306-0  
Telefax (+49) (69) 8306-555

## Certificates

**EG-Konformitätserklärung im Sinne der elektromagnetischen Verträglichkeit (EMV)**  
**EC Declaration of conformity for EMC**



### **Konformitätserklärung** **Declaration of Conformity**

In Übereinstimmung mit der EG-Richtlinie 89/336/EWG, Artikel 10, Anhang 1  
und in Übereinstimmung mit der EG-Niederspannungsrichtlinie 73/23/EWG  
*In accordance with the EEC Directive 89/336/EEC, Article 10, Annex 1  
and in accordance with the EEC low voltage Directive 73/23/EEC*

Wir, ASB GmbH, Im Sand 14, 76669 Bad Schönborn/Langenbrücken, erklären hiermit, daß  
das Produkt der Serie  
*We ASB GmbH, Im Sand 14, 76669 Bad Schönborn/Langenbrücken, declare that the  
product of the series*

**APOLLO 3G® - Kompakt**

den folgenden Vorschriften entspricht:  
*meets the following standards:*

EN 50081-1, EN 50081-2  
EN 50082-1, EN 50082-2  
EN 50011 Klasse B  
prDIN EN 50178 (VDE 0160):1994-11  
EN 50178:1997-7 (rat)

Dies gilt unter der Voraussetzung, daß Einsatz, Installation und Netzfilter den  
Vorgaben im Produkthandbuch und den Installationshinweisen entsprechen.

*This applies under the condition that the installation, application and line filters  
meet the specifications in the product manual and the installation instructions.*

Dipl.-Ing. (FH) Andreas Schweininger  
Geschäftsführer  
ASB GmbH

Dipl.-Ing. Erich Ehlen  
Betriebsleiter  
ASB GmbH

17.09.1997  
Datum / Date

ASB Gesellschaft für Positionier- und Antriebssysteme mbH  
Im Sand 14  
76669 Bad Schönborn - Langenbrücken



# 15 Index

## 7

7- Segment-display .....59,60

## A

Analog setpoint .....49

## B

BIAS- commands .....69

BIAS- extended command overview .....71

Brake resistor .....46

## C

Commissioning .....55, 56, 57, 58

Commissioning in steps .....56, 57, 58

Communication .....11

Compact units 635/K DER .....15

Control cabinet - mounting .....43

Control cabling .....49

Control circuit .....64

Control signal plug X10 .....25

Controllersystem .....66

Cooling .....43

## D

Danger areas .....44

Description X40 .....29

Diagnosis .....11

Diagnosis and trouble shooting .....59, 60, 61, 62

Digital communication .....11, 65

Digital control .....65

Dimensions and layout .....19

Disposal .....67

## E

EASYRIDER .....68

Electrical installation .....44

Electromagnetic compatibility (EMC) .....49

Example for mounting .....51

## F

Fieldbus interface COM2 .....34

Fuses, contactors, filters .....45

## G

General .....9

General technical data .....64

Generally data .....14

Ground connections .....44

Grounding, safety grounding .....44

## H

Hints for mounting .....50

## I

Installation of the rack .....49

Insulation concept .....14

## J

Jumper .....53

## K

Key to the models .....13

## L

Layout .....21

## M

Mechanical data .....66

Mechanical installation .....43

Mounting .....43

## O

Operating modes .....39

Operating via PROG-key .....54

Operation configurations .....11

Output power .....18

## P

Pin assignment for CAN .....36

Pin assignment for I/O-Interface .....38

Pin assignment for Interbus S .....37

Pin assignment for Profibus DP .....36

Pin assignment for RS232 .....35

Pin assignment for RS422/485 .....35

Pin assignment for SUCOnet K .....36

Plug-in modules 635/DER .....16

Power cabling .....49

Power circuit .....64

Power connections .....23

Preparation .....55

PROG-key functions .....53

## R

Range data .....14

Remote IN .....37

Remote OUT .....37

Reset of a regulator trouble .....61

Resolver evaluation .....65

## S

Safety .....44

Safety precautions .....7

Safety rules .....49

Selection of the brake resistor .....46

Setting and programming .....53

Signal connections .....25

Signal inputs and outputs .....64

Single- and three-phase supply .....17

Software .....68, 69

Stepper motor input .....32

System description .....9, 10

System variants .....9

## T

The danger of electric shocks .....44

Thermal data .....66

Trouble shooting .....62

## W

Wiring instructions .....49

## 16 Notes



## 17 Modification Record

Version	Modification	Chapte	Date	Name	Comment
V07.44STPL98	Documentation scheduled like 637 drive and technical data updated		02.11.1998	K. Stadler	Eurotherm-Format
V08.19STPL99	System variants updated text addition text addition new chapter text addition current consumption X40 inserted text addition text addition text addition BIAS commands updated new chapter	1.1 1.2 1.4.2 2.2.1.2 2.2.2.2.2 2.2.2.3  2.2.3.1 2.2.3.2 4.2 13.2 15	11.05.1999	K. Stadler	
V09.21STPL99	RESET function addition BIAS commands updated	9.2 13.2	17.06.1999	SA/ST	
V1001	complete modification seperation German / English	all	11.01.2002	N.Dreilich	Eurotherm-Format

<b>AUSTRALIA</b> Eurotherm Pty Ltd.	Unit 10 40 Brookhollow Avenue Baulkham Hills New South Wales 2153	Tel.: +61 (2) 9634 8444 Fax: +61 (2) 96348555	<a href="http://www.eurotherm.com.au">http://www.eurotherm.com.au</a> <a href="mailto:eurotherm@eurotherm.com.au">eurotherm@eurotherm.com.au</a>
<b>AUSTRIA</b> Eurotherm GmbH	Geiereckstrasse 18/1 A1110 Vienna	Tel.: +43 (1) 798 7601 Fax: +43 (1) 798 7605	<a href="http://www.eurotherm.at">http://www.eurotherm.at</a> <a href="mailto:eurotherm@eurotherm.at">eurotherm@eurotherm.at</a>
<b>BELGIUM</b> Eurotherm BV	Rue du Val-Notre-Dame 384 B-4520 Moha	Tel.: +32 85274080 Fax: +32 85274081	<a href="mailto:sales@eurotherm-belgium.be">sales@eurotherm-belgium.be</a>
<b>CANADA</b> Eurotherm Drives	530 Seaman Street Unit 3 Stoney Creek Ontario L8E 3X7	Tel.: +1 (905) 664 8911 Fax: +1 (905) 6645869	<a href="mailto:andy.wright@drives.eurotherm.com">andy.wright@drives.eurotherm.com</a>
<b>DENMARK</b> Eurotherm Drives Danmark	Enghavevej 9D DK-7100 Vejele	Tel.: +45 (70) 201311 Fax: +45 (70) 201312	<a href="mailto:leif.tangaa@eurotherm.se">leif.tangaa@eurotherm.se</a>
<b>FRANCE</b> Eurotherm Vitesse Variable SA	15 Avenue de Norvège Villebon / Yvette 91953 Courtaboeuf Cedex Paris	Tel.: +33 1 (69) 185151 Fax: +33 1 (69) 185159	
<b>GERMANY</b> Eurotherm Antriebstechnik GmbH	Von-Humboldt-Strasse 10 64646 Heppenheim	Tel.: +49 (6252) 798200 Fax: +49 (6252) 798205	<a href="http://www.eurotherm.de">http://www.eurotherm.de</a> <a href="mailto:info@eurotherm.de">info@eurotherm.de</a>
<b>HONG KONG</b> Eurotherm Ltd.	Unit D 18/F Gee Chang Hong Centre 65 Wong Chuk Hang Road Aberdeen	Tel.: +852 2873 3826 Fax: +852 2870 0148	<a href="mailto:eurotherm@eurotherm.com.hk">eurotherm@eurotherm.com.hk</a>
<b>INDIA</b> Eurotherm India Ltd.	152 Developed Plots Estate Perungudi Chennai 600 096	Tel.: +91 (44) 496 1129 Fax: +91 (44) 496 1831	<a href="mailto:svs@euromds.rpgms.ems.vsnl.net.in">svs@euromds.rpgms.ems.vsnl.net.in</a>
<b>IRELAND</b> Eurotherm Ireland Ltd.	I.D.A. Industrial Estate Monread Road Naas Co. Kildare	Tel.: +353 (45) 879937 Fax: +353 (45) 875123	
<b>ITALY</b> Eurotherm Drives SPA	Via Gran Sasso 9 20030 Lentate Sul Seveso Milano	Tel.: +39 (0362) 557308 Fax: +39 (0362) 557312	<a href="http://www.eurothermdrives.it">http://www.eurothermdrives.it</a> <a href="mailto:info@eurothermdrives.it">info@eurothermdrives.it</a>
<b>JAPAN</b> Nemic-Lambda KK Eurotherm Division	Denpa Building 1-11-15 Higahi Gotanda Shinagawa-Ku Tokyo 141-0022	Tel.: +81 (3) 3447 6441 Fax: +81 (3) 3447 6442	<a href="http://www.eurotherm.com/japan.htm">http://www.eurotherm.com/japan.htm</a> <a href="mailto:II9K-IWM@asahi-net.or.jp">II9K-IWM@asahi-net.or.jp</a>
<b>KOREA</b> Eurotherm Korea Ltd.	3F J-Building 402-3 Poongnab-Dong Songpa-Ku Seoul 138 040	Tel.: +82 (2) 478 8507 Fax: +82 (2) 488 8508	
<b>NETHERLANDS</b> Eurotherm BV	Genielaan 4 2404CH Alpen aan den Rijn Holland	Tel.: +31 (172) 411 752 Fax: +31 (172) 417 260	<a href="http://www.eurotherm.nl">http://www.eurotherm.nl</a> <a href="mailto:sales@eurotherm.nl">sales@eurotherm.nl</a>
<b>NORWAY</b> Eurotherm Drives Norge	Postboks 650 1411 Koltbotn Oslo	Tel.: +47 (66) 992550 Fax: +47 (66) 803131	<a href="mailto:eurotherm@online.no">eurotherm@online.no</a>
<b>SPAIN</b> Eurotherm Espana SA	Calle La Granja 74 Pol. Ind. Alcobendas 28108 Madrid	Tel.: +34 (91) 6616001 Fax: +34 (91) 6619093	<a href="mailto:eurotherm@teleline.es">eurotherm@teleline.es</a>
<b>SWEDEN</b> Eurotherm Drivteknik AB	Box 9084 S-30013 Halmstad	Tel.: +46 (35) 177300 Fax: +46 (35) 108407	<a href="http://www.eurotherm.se">http://www.eurotherm.se</a> <a href="mailto:info.drives@eurotherm.se">info.drives@eurotherm.se</a>
<b>SWITZERLAND</b> Eurotherm Produkte (Schweiz) AG	Schwerzistrasse 20 CH 8807 Freienbach	Tel.: +41 (55) 4154400 Fax: +41 (55) 4154415	<a href="mailto:epsag@eurotherm.ch">epsag@eurotherm.ch</a>
<b>UK</b> Eurotherm Drives Ltd.	New Courtwick Lane Littlehampton West Sussex BN17 7RZ	Tel.: +44 (0) 1903 737000 Fax: +44 (0) 1903 737100	<a href="http://www.eurotherm.co.uk">http://www.eurotherm.co.uk</a> <a href="mailto:info@eurotherm.co.uk">info@eurotherm.co.uk</a>
<b>U.S.A.</b> Eurotherm Drives Inc.	9225 Forsyth Park Drive Charlotte North Carolina 28273	Tel.: +1 (704) 588 3246 Fax: +1 (704) 588 3249	<a href="http://www.eurothermdrives.com">http://www.eurothermdrives.com</a> <a href="mailto:russ.fulle@drives.eurotherm.com">russ.fulle@drives.eurotherm.com</a>

## Eurotherm Antriebstechnik GmbH

Im Sand 14 • D-76669 Bad Schönborn • Telefon 07253-940 40 • Fax 07253-940 499

E-Mail: [info@eurotherm.de](mailto:info@eurotherm.de) • Internet <http://www.eurotherm.de>